

---

## Maglev: Transport Mode For the 21st Century

---

*Drs. James Powell and Gordon Danby tell how magnetic levitation can revolutionize world transport, in this article reprinted from 21st Century Science & Technology, Summer 2003.*

---

Maglev is a completely new mode of transport that will join the ship, the wheel, and the airplane as a mainstay in moving people and goods throughout the world. Maglev has unique advantages over these earlier modes of transport and will radically transform society and the world economy in the 21st Century. Compared to ships and wheeled vehicles—autos, trucks, and trains—it moves passengers and freight at much higher speed and lower cost, using less energy. Compared to airplanes, which travel at similar speeds, Maglev moves passengers and freight at much lower cost, and in much greater volume. In addition to its enormous impact on transport, Maglev will allow millions of human beings to travel into space, and can move vast amounts of water over long distances to eliminate droughts.

In Maglev—which is short for MAGnetic LEVitation—high-speed vehicles are lifted by magnetic repulsion, and propelled along an elevated guideway by powerful magnets attached to the vehicle. The vehicles do not physically contact the guideway, do not need engines, and do not burn fuel. Instead, they are magnetically propelled by electric power fed to coils located on the guideway.

Why is Maglev important? There are four basic reasons.

**First**, Maglev is a much better way to move people and freight than by existing modes. It is cheaper, faster, not congested, and has a much longer service life. A Maglev guideway can transport tens of thousands of passengers per day along with thousands of piggyback trucks and automobiles. Maglev operating costs will be only 3 cents per passenger

mile and 7 cents per ton mile, compared to 15 cents per passenger mile for airplanes, and 30 cents per ton mile for inter-city trucks. Maglev guideways will last for 50 years or more with minimal maintenance, because there is no mechanical contact and wear, and because the vehicle loads are uniformly distributed, rather than concentrated at wheels. Similarly, Maglev vehicles will have much longer lifetimes than autos, trucks, and airplanes.

**Second**, Maglev is very energy efficient. Unlike autos, trucks, and airplanes, Maglev does not burn oil, but instead consumes electricity, which can be produced by coal-fired, nuclear, hydro, fusion, wind, or solar power plants (the most efficient source now being nuclear). At 300 miles per hour in the open atmosphere, Maglev consumes only 0.4 megajoules per passenger mile, compared to 4 megajoules per passenger mile of oil fuel for a 20-miles-per-gallon auto that carries 1.8 people (the national average) at 60 miles per hour (mph). At 150 mph in the atmosphere, Maglev consumes only 0.1 of a megajoule per passenger mile, which is just 2 percent of the energy consumption of a typical 60-mph auto. In low-pressure tunnels or tubes, like those proposed for Switzerland's Metro system, energy consumption per passenger mile will shrink to the equivalent of 10,000 miles per gallon.

**Third**, Maglev vehicles emit no pollution. When they consume electricity, no carbon dioxide is emitted. Even if they use electricity from coal- or natural-gas-fired power plants, the resulting CO<sub>2</sub> emission is much less than that from autos, trucks, and airplanes, because of Maglev's very high energy efficiency.

Maglev has further environmental benefits. Maglev vehicles are much quieter than autos, trucks, and airplanes, which is particularly important for urban and suburban areas. Moreover, because Maglev uses unobtrusive narrow-beam elevated guideways, its footprint on the land is much smaller than

*This article was submitted as a discussion document for the Schiller Institute's Sept. 15-16, 2007 conference in Kiedrich, Germany, on the Eurasian Land-Bridge.*



Transrapid

*In the German Transrapid system, electromagnets are attracted upwards to iron rails at the edges of a T-shaped guideway beam, providing the magnetic force to levitate the vehicle.*

that of highways, airports, and railroad tracks.

**Fourth**, Maglev has major safety advantages over highway vehicles, trains, and airplanes. The distance between Maglev vehicles on a guideway, and the speed of the vehicles, are automatically controlled and maintained by the frequency of the electric power fed to the guideway. There is no possibility of collisions between vehicles on the guideway. Moreover, since the guideways are elevated, there is no possibility of collisions with autos or trucks at grade crossings.

### How Does Maglev Work?

Maglev has been a dream since the early 1900s. Emile Bachelet proposed to magnetically levitate trains using attached alternating current (AC) loops above conducting metal sheets, such as aluminum, on the ground. Other ideas followed, based on conventional electromagnets and permanent magnets. However, all these proposals were impractical. Either power consumption was too great, or the suspension was unstable, or the weight that could be levitated was too small.

The first practical Maglev system was proposed and published by us in 1966.<sup>1</sup> It was based on Maglev vehicles carrying lightweight superconducting magnets that induced currents in a sequence of ordinary aluminum loops mounted along a guideway. These induced currents interacted with the superconducting magnets on the vehicle, levitating it above the guideway. The levitated vehicle is inherently and passively stable against all external forces, including cross-winds, and the centrifugal forces on curves, whether horizontal or vertical. If a cross-wind tries to push the vehicle sideways, an opposing magnetic force is automatically generated that holds the vehicle on the guideway. If the vehicle is pushed down towards the

guideway, the levitation force automatically increases, preventing contact. If an external force lifts the vehicle away from the guideway, the levitation force decreases, and the vehicle drops back towards its equilibrium suspension height.

The levitation process is automatic, as long as the vehicle moves at a speed above its lift-off speed. Below this speed, which is in the range of 20 to 50 mph depending on design, the finite electrical resistance of the aluminum loops on the guideway decreases the induced currents to the point where the magnetic force is too weak to levitate the vehicle. The vehicle is supported at low speeds by auxiliary wheels, or by locally powering the guideway. These lower-speed sections of guideway are very short and are needed only when a vehicle accelerates out of a station or decelerates into it.

Our 1966 paper sparked intense interest in Maglev in many countries. It was

quickly realized that superconducting magnets made Maglev practical. Basically, superconducting magnets are extremely powerful and lightweight permanent magnets. Because they have zero electrical resistance, even when they carry currents of hundreds of thousands of amps, their power consumption is zero, except for a very small amount of electric power for the refrigerators which keep the superconductor at cryogenic temperature.

After our 1966 publication, Maglev programs started in the United States, Japan, Germany, and other countries. Sadly, U.S. Maglev development stopped in the early 1970s (although it has since recommenced—more on that later), when the Department of Transportation decided that High Speed Rail and Maglev were not needed in the United States because auto, trucks, and airplanes would suffice for the indefinite future.

However, major development programs continued in Japan and Germany. Japan focussed on superconducting Maglev, and now has a commercially ready passenger Maglev system based on our original inventions. Japan Railways operates Maglev vehicles at speeds up to 350 mph on their 20-kilometer guideway in Yamanashi Prefecture. Japan Railways vehicles operate in the open atmosphere and in deep mountain tunnels, both as individual units, and as linked sets of up to five units.

The basic features of superconducting Maglev are a U-shaped guideway similar to the one in Japan. The set of passive, null-flux aluminum loops on the sidewalls of the guideway levitates and laterally stabilizes the moving vehicle. The vehicle is magnetically propelled along the guideway by a second set of aluminum loops on the sidewalls, called the Linear Synchronous Motor (LSM). The LSM loops are connected to a power line through electronic switches. When ener-

gized, the AC current in the LSM loops pushes on the superconducting loops attached to the vehicle, causing it to move along the guideway.

The LSM propulsion acts like a conventional rotary synchronous motor, except that it is linear instead of cylindrical. It pushes the Maglev vehicles at a constant speed that is fixed by the frequency of the AC current in the LSM loops, regardless of whether there are head or tail winds, or the vehicles are climbing or descending a grade. The spacing between vehicles always stays the same, making collisions impossible. Linear Synchronous Motor propulsion is very efficient—more than 90 percent of the electric power fed to the LSM loops ends up as drive power to the vehicles.

Japan Railways plans a 300-mile Maglev route between Tokyo and Osaka, to carry 100,000 passengers daily with a trip time of one hour. More than 60 percent of the route would be in deep tunnels through the mountains in the center of Japan. The proposed route would open this region, now sparsely populated, for development. Japan has spent more than \$2 billion in developing its Maglev system, and Japan Railways' Maglev vehicles have clocked over 200,000 kilometers on the Yamanashi guideway, carrying tens of thousands of passengers.

### Germany's Transrapid

Germany has followed a different path to Maglev. Instead of using superconducting magnets, the German Transrapid system uses conventional room-temperature electromagnets on its vehicles. The photo on page 52 shows how the electromagnets are attracted upwards to iron rails at the edges of a T-shaped guideway beam, providing the magnetic force needed to levitate the vehicle. However, in contrast to superconducting Maglev, which has an inherently stable magnetic levitation force, the Transrapid magnetic levitation force is inherently unstable. In superconducting Maglev, as the vehicle gets closer to the guideway, its magnetic repulsive force becomes greater, automatically pushing it away from the guideway. In electromagnetic Maglev, as the vehicle gets closer to the guideway, the magnetic attractive force becomes greater, automatically pulling it closer to the guideway. To prevent the high-speed vehicles from being drawn up to and into contact with the guideway, and to overcome this inherent instability, Transrapid uses a servo control system that continuously adjusts the magnet current, on a time scale of thousandths of a second, to maintain a safe gap between the vehicle electromagnets and the iron rails on the guideway.

Because the electromagnets consume substantial amounts of electric power to generate their magnetic field, the gap between the Transrapid vehicle magnets and the guideway must be small, on the order of one-third of an inch. In contrast, vehicles that use superconducting magnets are 4 inches or more

FIGURE 1  
Maglev 2000 of Florida Vehicle Parameters

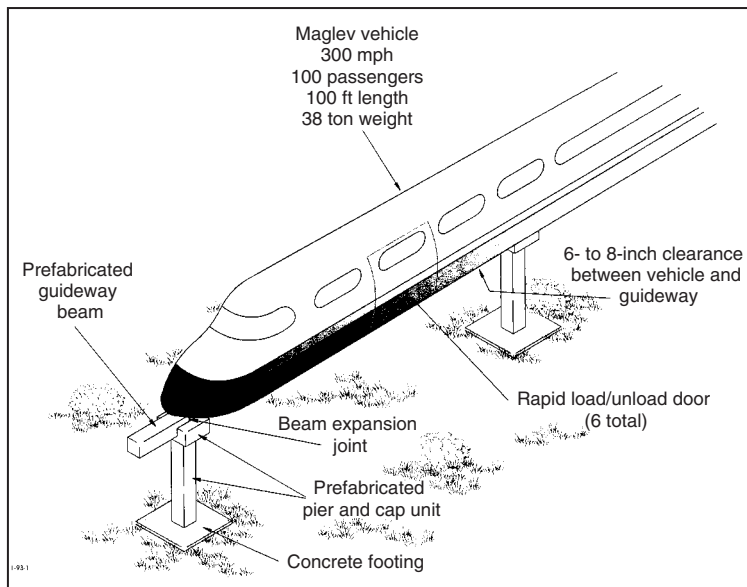

An M-2000 vehicle on a prefabricated narrow-beam guideway.

away from the guideway. Transrapid vehicles have also logged hundreds of thousands of kilometers on their test track in Emsland, Germany, and carried tens of thousands of passengers at speeds up to 280 mph smoothly and safely. The world's first commercial Maglev system went into operation in December 2002 in Shanghai, China. The 30-kilometer Transrapid route carries passengers between the center of Shanghai and its airport.

In our view, superconducting Maglev systems are better than electromagnetic or permanent magnet ones. The much greater clearance of the superconducting systems enhances safety and greatly mitigates the problems of snow and ice buildup in colder regions. Large clearance also permits greater construction tolerances, substantially reducing the cost of the guideway. Second, because a superconducting Maglev system can carry heavy trailers and freight as well as passengers, its revenue potential is much greater. Finally, the inherent very strong stability of superconducting Maglev systems helps to guarantee that safe operation is maintained at all times.

Implementing the first-generation Japanese and German Maglev systems has been hindered by the \$40 million to \$60 million per mile cost of their guideways. Assuming a daily ridership of 30,000 passengers—high for the United States—a \$50 million per mile Maglev route with a net revenue of 10 cents per passenger mile (ticket revenues minus operating and maintenance costs) would take 50 years to pay back its construction cost.

Highway and air transport systems have historically been—and continue to be—heavily subsidized by the U.S. government. Indeed, investment by government into more ef-

efficient modes of transport increases the productivity of the whole economy, and thus pays for itself in added economic output. However, because of the current large budget deficits, the weak economy, and even weaker economic thinking, a new mode of transport like Maglev is unlikely to be supported by the present government unless it can pay back its cost within a few years. Moreover, if Maglev systems can be paid back quickly, they will attract private investment.

To achieve this fast payback capability, we are now developing a second-generation superconducting Maglev System that will be much less expensive to build, and that will produce much greater revenues by carrying piggyback trailers and automobiles. This second-generation system is described in the next section. Initial levitation tests of the system will be carried out this year [2003] at our Maglev-2000 of Florida facility, with funding from the U.S. and Florida Departments of Transportation.

### Moving People and Freight

The second-generation Maglev-2000 system achieves four major innovations over the first-generation Japanese and German systems:

- (1) Much lower guideway cost—\$12 million per mile, compared to \$40 million to \$60 million per mile.
- (2) Much faster payback times—5 years instead of 50, by carrying piggyback trucks.
- (3) Electronic switching of vehicles at high speeds from the main guideway to off-line stations for loading and unloading.
- (4) Ability to use existing, conventional railroad tracks for Maglev vehicles.

Key to these innovations are three fundamental Maglev-2000 inventions:

- Mass-produced, low-cost, prefabricated guideway beams and piers.
- Quadrupole magnets (with two pairs of North-South poles, at right angles to each other), which enable vehicles to travel on, and smoothly transition between, both narrow beam and planar guideways.
- Electronic switching from the main guideway to secondary guideway, without any mechanical movement of the guideway's structures.

**Figure 1** shows an M-2000 vehicle on a prefabricated narrow-beam guideway. The prefabricated, conventional, reinforced concrete box beams, with their attached aluminum-loop panels, are mass produced at low cost at a factory. The beams are then shipped from the factory, by truck or rail, to the Maglev construction site, along with the prefabricated piers. The only field construction required is the small poured concrete footings for the piers. Cranes lift the beams and piers into place, allowing a complete guideway route to be erected in a few weeks. The beams and piers can also be transported along finished portions of the guideway to the erection site, eliminating the need for road or rail transport. The projected cost of \$12 million per mile for the M-2000 elevated narrow

**FIGURE 2**  
**Passenger and Freight Vehicles on the M-2000 Guideway**

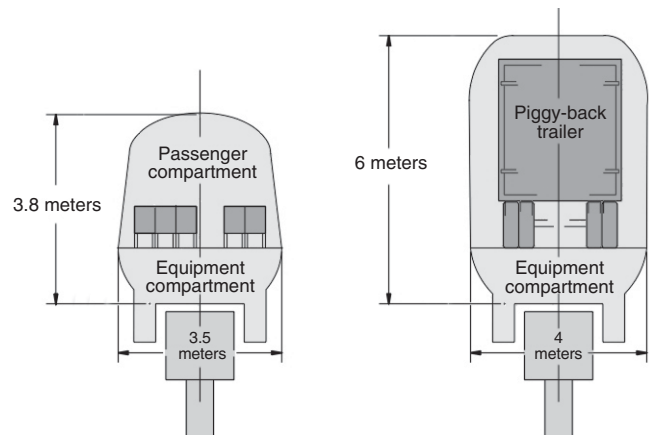

*The schematic drawings show the relative size and configuration of Maglev-2000 passenger and freight vehicles.*

beam guideway is based on our fabrication experience for full-size guideway components, including the beam. The projected costs do not include land purchase or modification of existing infrastructure.

Maglev is usually pictured as a high-speed train for intercity passengers, or as a lower-speed system for urban transit. Although these are important applications, the big market for freight transportation in the United States is intercity trucking. The United States currently spends more than \$300 billion annually on intercity trucking, compared to only \$65 billion per year on intercity air passengers. The biggest intercity air passenger route, Los Angeles to and from New York, carries only about 10,000 passengers daily, while many U.S. Interstates carry 15,000 trucks per day, with some highways carrying more than 25,000 trucks daily. A Maglev route carrying 2,000 trucks per day—20 percent or less of the daily traffic—would take in as much revenue as a route carrying 100,000 passengers per day, which is 10 times greater than the largest intercity air passenger market in the United States.

The average haul distance for intercity trucks is more than 400 miles, with many travelling 1,000 miles or more. Using Maglev, truckers could pick up a load and drive it a few miles to the nearest station. The trailer would be put onto a Maglev vehicle (**Figure 2**), taking only a couple of minutes. At 300 miles per hour, the trailer could cross the country from California to New York in a few hours, instead of taking days by highway. After arriving at a station near its destination, the trailer would be unloaded and driven to the customer. Everyone would benefit: The shipper would pay less to transport his goods, and could shrink inventory by just-in-time delivery; the shipping company would make more money, and reduce wear and tear on its trucking fleet; and the drivers would not



**FIGURE 3**  
**Economic Advantages of Maglev Carrying Both Passengers and Trucks**

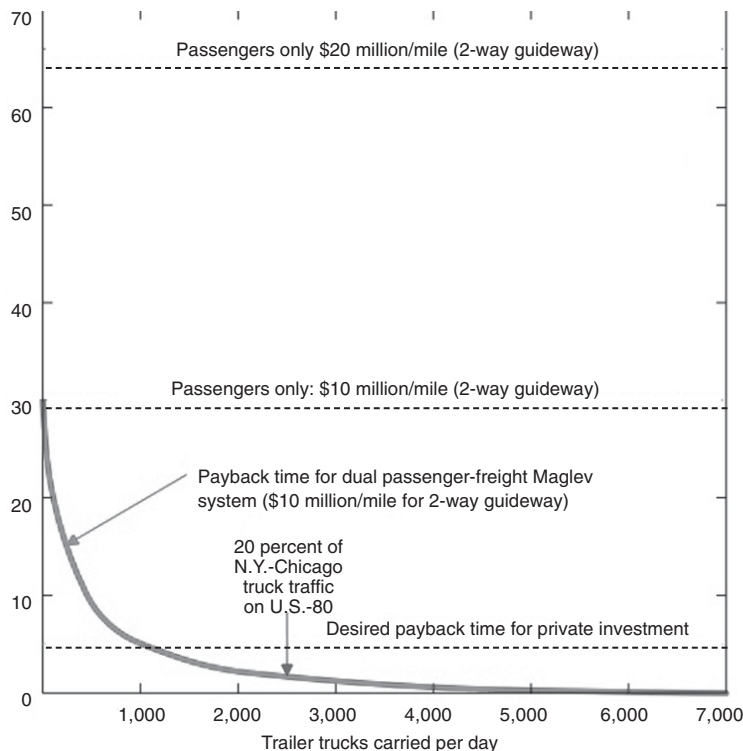

The figure shows the time it takes to pay back the cost of the Maglev guideway carrying passengers only, and a dual system that carries both passengers and freight. The conditions used in the calculation are 3 million passengers per year, at 10 cents per passenger mile, net revenue, and 25 tons per trailer truck at 20 cents per ton-mile revenue.

need to spend long, tiring hours on the road.

**Figure 3** shows the economic advantage for Maglev to carry trucks as well as passengers. Even at \$10 million per mile for the Maglev-2000 guideway—well below the \$40 million to \$50 million per mile for the German and Japanese systems—paying back the guideway takes 30 years. However, by carrying 2,500 trucks daily—only 20 percent of the truck traffic between New York and Chicago—payback time drops to just three years. Short payback times will help attract massive private investment, aiding the rapid implementation of Maglev.

### Unique, High-Speed Train Switching

In addition to attractive economics, Maglev must be easily accessible and efficiently integrated with other modes of transport. Maglev-2000 is unique in its ability to electronically switch high-speed vehicles from one guideway to another, without having to slow down the trains, and mechanically move sections of the guideway, as do the German and Japanese systems. The superconducting quadrupole magnets on

the Maglev-2000 vehicles allow them to smoothly transition, back and forth, between narrow-beam and planar guideways. Most of the time, the vehicle rides on the low-cost, narrow-beam guideway, where the sides of the quadrupoles magnetically interact with aluminum loops attached to the sides of the beam to levitate and automatically stabilize the vehicle. At locations where the vehicle may switch off the guideway, it transitions to a planar guideway, where the bottom of the quadrupoles magnetically interacts with the aluminum loops on the guideway beneath, levitating and stabilizing the vehicle.

At switch locations, the vehicle can either continue along the main guideway, or electronically switch, at full speed, to a secondary guideway that leads to an off-line station. The switch section contains two lines of aluminum loops. Depending on which line of loops is activated when the vehicle enters the switch, it can either keep going on the main guideway, or switch to the secondary one. The vehicle slows down on the secondary guideway, and stops at the station to unload passengers, or a truck, and pick up a new load. It then accelerates out of the station on the secondary guideway, to rejoin the main guideway at full speed.

Maglev-2000 systems can thus have many stations in an urban/suburban region, without sacrificing high speed and short trip times. Users would board a Maglev vehicle at a nearby station and travel at full speed to a station close to their destination, without stopping at intermediate stations. Unlike airports, which are limited to one or two locations in a given urban/suburban region, making access difficult and time-consuming, Maglev can have 10 or 20 stations, or more, in a given region.

### A National Maglev Network

In addition to easy access, for Maglev to be a major mode of transport, it must function as an integrated, interconnected network. Isolated, separate point-to-point Maglev systems could be useful, but would not provide the broad transport capability needed in the 21st Century. The National Maglev Network proposed by Maglev-2000 is a 16,000-mile network, which would be built on the rights-of-way land alongside the U.S. Interstate highways, serves 90 percent of the population. Major metropolitan regions would have multiple stations, as described above, with the result that 70 percent of Americans would be living within 15 miles of a Maglev station. Travelers could reach any destination in the United States, and the major cities in Canada, within a few hours of leaving their house, while trucks could cross the continent in less than 10 hours.

Travel on Maglev would be much more comfortable than by air. There would be no noise or vibration, no turbulence,

and all passengers would ride in comfortable, first-class-type seating. Maglev vehicles will cost much less than airplanes, and are not space constrained, so there is no need to jam passengers together to maximize loading. Because Maglev fares will be much less than those for air travel, passenger volume will be greater, allowing more frequent and convenient scheduling. Instead of one or two flights daily to a particular destination, there will be hourly, or even more frequent, Maglev departures.

The cost to construct the Maglev-2000 National Network is projected to be about \$200 billion. Although this is a large sum of money, it is equivalent to only two months of the annual U.S. transportation bill of \$1,200 billion, of which \$1,000 billion goes to autos and trucks. The transportation savings enabled by the U.S. Maglev Network would exceed \$100 billion annually, paying for the system in a couple of years. Unlike highways, autos, trucks, and airplanes, Maglev guideway and vehicles have no wear and tear, need virtually no maintenance or repair, and should last 50 years or more.

Maglev-2000 proposes to build the first U.S. Maglev System in Florida. There would be a 20-mile route connecting the Port Canaveral Seaport and the Space Coast Regional Airport in Titusville, with an intermediate station at the Kennedy Space Port. The M-2000 line would carry cruise passengers to the seaport and visitors to the Kennedy Space Center; it would also demonstrate the transport of trucks and freight to and from the seaport. Once operating, the M-2000 line would act as a convincing demonstration of the practicality and desirability of Maglev transport, and would help spur the construction of Maglev routes at many other locations in the United States. With a vigorous construction effort, the National Maglev Network could be in full operation well before the year 2020.

## The Great Trans-Siberian Land Bridge

The growing world economy requires the movement of ever larger amounts of people and goods over long distances. In particular, China, India, and other rapidly developing Asian countries, where most of the world's population lives, need modern, efficient, and low-cost transport systems that connect with Europe, America, and the rest of the world. Although most travellers to and from Asia now go by air, ships still move most of the goods. There are drawbacks for ship transport to Asia: The distances and travel times are very long, shipping costs are expensive, and ships consume a significant fraction of the world oil production.

As an example, the shipping distance between Japan and Europe is 12,000 miles via the Suez Canal (18,000 miles for the Cape of Good Hope route), and the trip takes several weeks. At 1-cent per ton mile, the shipping cost from Asia to Europe is \$100, or more, per ton of cargo. World shipping presently consumes approximately 7 percent of the world's oil production, a significant drain on oil resources. For much of the world's long-distance transport, Maglev can move

goods much faster, cheaper, and with less energy use than can ships. For example, by using the existing Trans-Siberian railroad structure, Maglev could transport cargo between Europe and the Far East in only one day (compared to weeks by ship), at a much lower cost, and using much less energy.

*EIR's Special Report* on the Eurasian Land Bridge,<sup>2</sup> shows the present railroad routes connecting the Far East with Europe and other Asian countries. The report describes how these routes, combined with a network of new rail lines, could help to develop and transform the region, by moving people and goods efficiently and cheaply. An interconnected Maglev system based on this railroad network can be quickly developed. The initial phase of the Maglev system would start with the existing 6,000-mile-long Trans-Siberian railroad. This Trans-Siberian route already carries substantial freight, approximately 100,000 Trailer Equivalent Units (TEUs) annually from Japan to Europe. At 25 metric tons per TEU, and 6,000 miles, this is equivalent to 15 billion ton-miles per year. Transport times are many days, however.

Building an elevated Maglev-2000 guideway along the Trans-Siberian route would cost \$60 billion, a formidable investment. However, there is a Maglev alternative that can enable a high-speed system at lower cost. This system uses existing railroad trackage to levitate high-speed Maglev vehicles, and can be built for only \$2 million dollars per mile. The M-2000 MERRI (Maglev Emplacement on Railroad Infrastructure) system attaches flat panels containing aluminum loops to the wooden or concrete ties of the existing trackage. The railroad can still operate conventional trains while the panels are being installed. After all of the panels are installed, Maglev operation on the resultant planar guideway can begin. The iron rails still remain in place, but they do not hinder Maglev operation. Using MERRI, Maglev vehicles would average 200 miles per hour across Siberia, travelling 6,000 miles in only 30 hours compared to a week by ordinary train. The energy amount and cost per trip would be modest—about 300 kilowatt hours and \$15 (at 5 cents per kilowatt-hour) per passenger, and 600 kilowatt hours and \$30 per ton of cargo. The total investment for the MERRI system is about \$15 billion, including installation of the planar guideway, stations, and an initial rolling stock of 400 Maglev vehicles. With its high speed capability, a single Maglev vehicle carrying 50 tons of cargo each way could transport 10,000 tons per year between the Far East and Europe.

Based on the *EIR* Silk Road Report, about 2 million tons of cargo is carried per year (1997 figures) on the Trans-Siberian Railroad, assuming 25 tons per TEU, with the traffic expected to grow substantially. With 400 Maglev vehicles, the MERRI Trans-Siberian route could transport 4 million tons of cargo per year. At \$100 per ton, this would be a revenue of \$400 million annually. Revenues would then grow rapidly as shippers begin to appreciate the MERRI route's benefits.

Total annual freight traffic in the United States is 3.7 trillion ton miles, or more than 10,000 ton miles per person. High

volumes of freight traffic are indispensable for good living standards, and reflect the necessary movement of foodstuffs, fuels, raw materials, and manufactured goods back-and-forth over long distances. Assuming similar per capita volumes of freight traffic, for the roughly 5 billion people who will live in the Eurasian continental land mass and its associated islands by the year 2050, freight traffic in the region will total more than 50 trillion ton-miles annually.

As traffic grows, the system would evolve, becoming larger and more capable. Other railroad routes would be converted to the MERRI system, new routes would be added, and dedicated Maglev guideways built. An intriguing possibility is the construction of a super-speed Maglev system across Siberia. In the super-speed Maglev-2000 system, described below, Maglev vehicles operate in an evacuated tunnel at 1/1,000th of normal ambient atmospheric pressure. Traveling at 2,000 mph, Maglev vehicles would make the 6,000-mile trip in only 3 hours, instead of the 30 hours for a Maglev vehicle in the open atmosphere. The energy cost for the trip would be less than \$1 per passenger, and about \$1 per ton of cargo.

The Trans-Siberian route is very appealing for super-speed Maglev. Because much of the terrain is flat and undeveloped, low-cost evacuated surface tubes can be used, instead of much more expensive underground tunnels, which are needed in regions having substantial populations and/or terrain changes. While the investment for a super-speed Trans-Siberian route is considerably greater than for a MERRI system—\$100 billion compared to \$15 billion—the increased traffic revenues and decreased operating cost would offset its greater cost.

There are many other places in the world where Maglev land bridges could aid economic development, and improve living standards. Some are outlined in the *EIR* Silk Road Report. As an example, the Trans-Siberian Maglev system could extend to the Bering Strait, where it would connect to an American-Canadian Maglev system. The Bering Strait is relatively narrow, about 50 miles across at the bridging point, and could be crossed by a bridge or tunnel. Both have been studied, and judged technically and economically practical.

Integration of North America—and eventually South America, through Mexico, Central America, and the Isthmus of Panama—with Eurasia and Africa would connect almost all of the world with high-speed, low-cost, energy-efficient transport of people and goods. Africa would connect to Europe, via the proposed Gibraltar bridge, and through Egypt to the Middle East. Of the seven continents, only Australia and Antarctica would not be in the world Maglev Network, although there are plans for Maglev across Australia.<sup>3</sup>

When could a world Maglev Network come into being? Clearly, it would evolve over decades. Initial sections, like the U.S. National Network and the Trans-Siberian Maglev route could operate in 10 to 15 years. The full world Network would be in full operation by 2040 to 2050.

## New York to Los Angeles in One Hour

Because there is no mechanical contact or friction between levitated Maglev vehicles and the guideway, in principle the Maglev speed is unlimited. However, there always are limits. In the ambient atmosphere, Maglev vehicles are limited, by air drag and noise, to a maximum of about 300 miles per hour. In Maglev tests, Japan Railways has operated at 350 miles per hour. Because air drag increases as speed cubed, this is a practical limit. Noise emission increases as the seventh power of speed, so that noise would limit speed to about 300 miles per hour, even if air drag did not.

In low-pressure tunnels, however, Maglev speed is virtually unlimited, at least for transport on Earth. The only limitations are the straightness of the guideway, which is not a problem for underground tunnels, and centrifugal effects, which are important only when close to orbital velocity, that is 8 kilometers/second (18,000 miles per hour).

At 2,500 miles per hour, travel time from New York to Los Angeles is only 1 hour. The energy expenditure per passenger would be negligible, about the equivalent of one quart of gasoline. In contrast, an airline passenger expends almost 100 gallons of jet fuel for the same trip. The reasons for the difference are simple. An airliner continuously burns fuel to stay aloft and overcome air drag, while the Maglev vehicle expends virtually no energy after it reaches cruise speed in the low-pressure tunnel (There is a small magnetic drag caused by the resistive losses in the aluminum guideway coils, but this is taken into account by the quart of gasoline.) Moreover, virtually all of the kinetic energy which the Linear Synchronous Motor (LSM) imparts to the Maglev vehicle when it accelerates to cruise speed, is recovered when the vehicle decelerates to stop at its destination. During deceleration, instead of acting as a motor, the Linear Synchronous Motor functions like a generator, converting the kinetic energy of the vehicle back into electricity, which is fed back to the electric grid.

The concept of super-speed Maglev in low-pressure tunnels has been studied over the last 20 years. The proposed Swiss Metro System would operate Maglev vehicles in low-pressure tunnels through the mountains. The planned Japan Railways 300-mile-long line between Tokyo and Osaka has 60 percent of the route in deep tunnels. The line could be built for low-pressure Maglev, although the relatively small time savings, that is, 20 minutes out of the nominal trip time of one hour, might not warrant the additional tunnel cost.

Tunnelling costs are currently high, but not impractically so. Tunnels cost on the order of \$30 million per mile in competent rock. The U.S. Superconducting Super Collider facility, for example, planned a 45-mile tunnel for the superconducting magnets that confined the 10-trillion electron volt colliding particle beams. Several miles of Superconducting Super Collider tunnel were excavated using a tunnel-boring machine. As tunnelling technology advances, costs should drop, making super-speed Maglev more economical. At an average of \$10 million per mile for a 15-foot diameter tunnel,

a two-tunnel Maglev system between New York and Los Angeles would cost \$50 billion. Intermediate stops at Cleveland, Chicago, and Denver would connect to the 300-mph open air National Maglev Network, allowing travellers to reach all the major metropolitan areas in the United States in a few hours. Although the National Network will operate first, super-speed Maglev will eventually connect the main Network hubs, as an ultra high speed overlay.

Super-speed Maglev technology is similar to, and actually simpler than, the open-air technology. There are no wind or weather problems, vehicle levitation and stability is not affected by vehicle speed changes, there are no curves, and no need for Linear Synchronous Motor propulsion on most of the guideway, because magnetic drag at cruise speed is very small.

### **StarTram: Riding Maglev Into Space**

So far, space travel has been a big disappointment—at least from the perspective of the millions of people who want to visit hotels in space, and jet to the Moon, Mars, and beyond. We ordinary folk have to be satisfied with television shots of the astronauts in the space station, and tiny robots looking down on the moons and planets of the Solar System. In many ways, we have lost ground since the 1960s and 1970s, when astronauts drove Rovers on the Moon, hit golf balls, and brought back gobs of Moon rock.

The cost of getting into space has not come down much over the last 40 years. It still costs \$5,000 to put a pound of payload into Low Earth Orbit, and much more to land it on the Moon. As for Mars—forget it. This is not surprising. Despite repeated attempts to build cheaper rockets to reach orbit, these rockets remain very complicated and expensive. Unfortunately, this is inherent. Payload fraction is small, only a few percent, and the engines and structure are stressed to their limits. If a person is fortunate enough, and willing to pay \$20 million for the trip, it is possible to spend a few days in orbit.

There is a better way. The cost of the energy to reach orbit is only 30 cents per pound, if one could do it efficiently without using a rocket. The StarTram Maglev system is that better way. By using electric energy to propel and accelerate spacecraft, Maglev can achieve speeds of 8 kilometers per second or more, enough to go into orbit or reach the Moon, without needing propellant. This greatly reduces the weight and cost of the spacecraft and makes the launch cost very low. Five kilowatt hours of electrical energy, (at an average cost in the U.S. of 6 cents per kilowatt hour) is equal to the kinetic energy of a pound of material travelling at 8 kilometers per second, the speed of an object in Low Earth Orbit.

There is a constraint and a problem in using Maglev to launch into space, however. The constraint is relatively minor, but the problem is major. First, the constraint: To reach super speeds, the acceleration process must take place in a low-pressure environment over a long path. As described in the previous section on the Los Angeles to New York super-speed

Maglev system, Maglev vehicles can travel at super speeds in low-pressure tunnels. The length of the tunnel needed to reach 8 kilometers per second will depend on the acceleration rate. For human passengers subjected to an acceleration of 2 g (2 times the Earth's gravity), an 800-mile long tunnel is required; for unmanned cargo craft, which could accelerate at 30 g without damage, a 60-mile tunnel is sufficient. Even at \$30 million per mile of tunnel, the amortized cost of a Maglev tunnel per pound of payload delivered to orbit would be small—less than the cost of energy.

The major problem, that of leaving the low-pressure tunnel and entering the atmosphere, is not as easily solved, unfortunately. At 8 kilometers per second, atmospheric heating and drag forces would quickly destroy the spacecraft, even if it entered the atmosphere at high mountain altitudes. However, there is a solution to this problem. A low-pressure Maglev launch tube, termed StarTram, can itself be magnetically levitated to extremely high altitudes—high enough that the atmospheric heating and drag forces, produced when the spacecraft leaves the tube and enters the atmosphere, become acceptable. At an altitude of 70,000 feet (about 13 miles), for example, atmospheric density is only 5 percent of the sea level value; at 105,000 feet (20 miles), it is only 1 percent. At such altitudes, today's spacecraft structures are strong enough to survive the heating and drag forces, without compromising the health and safety of passengers and cargo.

Levitating the StarTram launch tube to such altitudes, although a challenging task, is quite feasible. Large magnetic levitation forces, for example, several tons per meter of tube length, can be produced by the repulsion force between a set of superconducting cables attached to the tube, and a second set of superconducting cables located on the ground beneath. The two sets of cables carry oppositely directed supercurrents, generating a magnetic levitation force that substantially exceeds the weight of the launch tube and its cables. To hold the StarTram launch tube at a stable equilibrium height, lightweight high-strength tethers (Kevlar or Spectra) are attached to it and anchored at ground level. Using a combination of vertical and angled tethers, the launch tube is held in place even in the presence of high winds. The length of the tethers along the launch tube depends on what is needed to keep the tube at the proper angle, as it is pressed upward by the repulsive magnetic force.

The magnetic levitation force is very large, even at high altitudes. For example, if the launch tube cables carry 30 megamps of supercurrent, and the ground cables carry 100 megamps, the magnetic levitation force is 3 metric tons per meter of launch tube, at a vertical separation of 20 kilometers (66,000 feet) between the tube and ground. The levitation force increases with decreasing separation distance, being 6 metric tons per meter at 10 kilometers separation.

After the spacecraft reaches launch speed in the low-pressure Maglev tunnel located at ground level, it transitions to the StarTram launch tube, in which it coasts upwards to the



FIGURE 4

## A Spacecraft Launch in Low-density Atmosphere

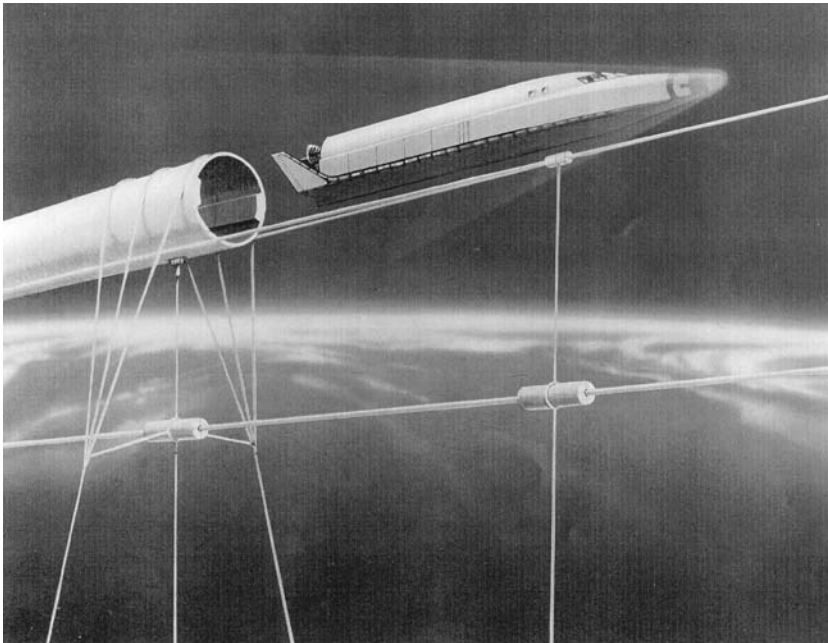

Artist's illustration of a StarTram launch.

release point in the upper atmosphere. Upon reaching the upper end of the launch tube, the spacecraft exits through the open end into the low-density atmosphere (**Figure 4**). The interior of the launch tube is kept at low pressure by a combination of auxiliary systems. These include a mechanical shutter that opens just before the spacecraft enters the launch tube, gas jet ejectors that start up when the shutter opens, and a magnetohydrodynamic (MHD) pump that expels any residual air that leaks past the gas jet ejector system. (A radiofrequency source ionizes the air in the MHD pump). Turbo molecular pumps supply additional pumping to help maintain low pressure in the launch tube.

After entering the atmosphere, the spacecraft coasts upwards through the small amount of residual atmosphere to orbital altitude, where it makes a small  $\Delta V$  (velocity change) burn to finalize the orbit. Depending on launch speed, the spacecraft can go into Low Earth Orbit, Geosynchronous Orbit, or any orbit in between. With slightly greater launch speed, it can reach the Lagrange points, or the Moon. As illustrated in Figure 4, the spacecraft would launch with its wings folded. For the return to Earth, the wings would deploy for atmospheric braking. Because a Maglev spacecraft does not use propellant, and its launch energy cost is virtually zero, weight is not an issue. Thus the StarTram spacecraft can be much stronger and more rugged, with much better thermal protection, than the Space Shuttle.

All of the technology for StarTram is available. The su-

perconductors, cryogenics, refrigerators, tethers, Maglev guideways, and spacecraft can be built with materials that already exist and are in use. This contrasts to the Space Elevator Concept, which requires structural materials that are 100 times stronger than any now in existence.

A single StarTram facility could launch a million tons of cargo, along with hundreds of thousands of passengers, per year into space. Flying into space would not cost much more than it now takes to fly around the world. If human beings really want to have hotels and manufacturing in space, a robust defense against asteroids, solar power satellites, colonies on the Moon and Mars, and so on, StarTram is the way to go.

## Maglev, Oil, and the World Economy

Modern transport is the indispensable backbone of a high living standard. Without autos, trucks, airplanes, railroads, ships, and pipelines, we would retreat to subsistence on small patches of land, farming for produce and gathering wild foods to sustain life. In turn, oil is the indispensable backbone of

modern transport. Without it, we would not have autos, trucks, and airplanes. Coal-fired railroads and ships could still operate, but much less capably.

The amount of oil in the world is limited. The presently known total world oil resources are only about 1 trillion barrels, about 30 years' worth at the current consumption rate of 80 million barrels per day. As living standards improve, and the world economy grows, the demand for oil will increase, resulting in an ever-greater rate of consumption. It is not possible to know precisely when the world will reach the point when oil runs out, because the date will depend on factors like the amount of oil deposits yet to be discovered, how difficult and expensive it will be to extract them, and how rapidly the world economy grows.

There is a clear fork in the road here. If the world continues to rely on oil for transport, its economy cannot grow much beyond the present level. In fact, the economy will shrink, and living standards will fall, as oil production declines. To maintain a growing world economy and an increasing standard of living, it will be necessary to shift to new modes and energy sources for transportation. New energy sources are possible, but there are limits. Hydrogen has been proposed as a long-range fuel for transport. However, enormous amounts of electricity would be needed to manufacture the hydrogen that would be needed, if it were to become the major energy source for transport.

The United States currently burns approximately 5 billion

barrels of oil per year for transport, which is approximately 70 percent of total U.S. usage. To produce the equivalent energy from hydrogen fuel would require 10 trillion kilowatt hours of new electric power—a factor of 3 greater than current U.S. electric generation. To meet the 2020 world demand for hydrogen fuel as a replacement for oil, would require constructing new electric generating capacity equivalent to 10 times the present world capacity. This is not a credible scenario. Hydrogen can be produced from coal, but the resultant CO<sub>2</sub> emissions would be much greater than those released by burning oil. Accordingly, hydrogen fuel does not appear to be a major practical solution for meeting the massive transport needs in the 21st Century.

Maglev, because it uses electric energy with very high efficiency, can meet 21st Century transport needs in a practical, energy efficient way. Maglev energy usage is a factor of 10 or more better than autos and airplanes. The total annual passenger traffic in the United States—autos, air and rail—is 2.5 trillion (2,500 billion) passenger miles. If all this travel were by Maglev at an average speed of 200 mph, the total electric energy use would be only 100 billion kilowatt hours, which is about 3 percent of the 3,700 billion kilowatt hours currently generated in the United States. The total annual freight traffic in the United States—trucks, rail, oil pipelines, and air—is 3.7 trillion ton-miles. Moving all freight by 200-mph Maglev would consume an additional 10 percent of current U.S. electric generation.

Moving all passengers and freight by Maglev would save more than 5 billion barrels of oil annually, or about 70 percent of our current consumption. The dollar savings in the costs of the crude oil, refining, and distribution would be enormous. At a savings of \$1 per gallon of current oil consumption, the nation's transport bill would be reduced by \$200 billion annually, far more than the cost of the electrical power to operate the Maglev. At the U.S. average production cost of 6 cents per kilowatt hour, only \$30 billion of electric power would be needed annually for the Maglev operation. In practice, of course, Maglev will not be the sole mode of transportation in the United States, so that the actual economic and energy benefits will be somewhat less than described above.

Clearly, it will take time to transition from the present auto, truck, and airplane-dominated transport system to a Maglev-dominated system. Moreover, because Maglev will never completely replace autos, trucks, and airplanes, it will operate in concert with them in multi-modal transport patterns. For example, Maglev will carry trucks for the bulk of their inter city travel, using the highway for local pickup and delivery. Similarly, passengers will be able to drive their autos to a Maglev station, and travel hundreds of miles with their car on a Maglev vehicle to a station near their destination, finishing their trip on the highway. The wear and tear on their automobiles would be much less, the travel time much shorter, the cost much smaller, and the trip much safer.

The benefits of improved mobility, greatly reduced energy consumption, freedom from having to depend on ever-shrinking oil resources, and the economic savings outlined above for the United States, will apply to the entire world, making Maglev the major mode of transport in the 21st Century.

### **The Maglev-2000 Water Train—Fresh Water for the World**

Maglev can help solve the world water shortage, by transporting fresh water from areas where it is plentiful, to areas where it is scarce. Water is the most critical natural resource problem facing the world today. Hundreds of millions of people lack sufficient clean water for drinking, washing, and farming, and the situation is growing worse, especially in Africa and Asia, where water tables are dropping as a result of over-pumping and droughts. In the United States, many regions are running out of water, including the Southwest, California, and the High Plains States. Even in the water-rich East, areas like Florida, Atlanta, and others have cut back on water consumption. World population is projected to grow from the present 6 billion to more than 9 billion by the year 2050, with much of the growth in regions that are already water short. This increase in population will require hundreds of trillions of gallons of new water annually. Experts believe that disputes over water rights could spark many new wars and conflicts in the coming decades.

Desalination is often proposed as the solution for future water shortages. Unfortunately, because it is expensive and energy intensive, it can supply only a small fraction of future world water needs. Desalination costs about \$6 per 1,000 gallons of fresh water produced, and consumes approximately 400 kilowatt hours of thermal energy. To supply all of the projected new needs for fresh water in 2050, using present desalination technology, would require \$3 trillion, 10 percent of current world GNP, and virtually all (100 percent) of current world energy usage. This is clearly impossible.

Some improvements in desalination technology appear possible. Using low-cost nuclear energy, instead of expensive fossil fuels, for example, would significantly reduce the desalination cost. Studies of nuclear desalination “nuplexes” have shown them to be attractive for meeting the drinking water and sanitary needs of populations in high GDP countries. However, even with improvements, desalination does not appear suitable for meeting the massive future water needs for agriculture, and for countries with low GDPs, where most of the world's population lives.

Maglev offers a practical cost-effective way to supply much of the new fresh water needs in the 21st Century. The world has plenty of fresh water to support its present and future populations, but many regions have too little, while others have much more than they need. Using Maglev, fresh water can be transported for hundreds of miles at low cost, from places where it is abundant, to users in locations where it is scarce.

**Figure 5** is an artist's illustration of the Water Train, a Maglev system designed to transport large amounts of water over long distances. The Water Train consists of a long train of joined and levitated Maglev vehicles, each of which has a bladder that holds 50,000 gallons of water. A 200-vehicle unit train would deliver 10 million gallons per trip. Travelling at 200 mph, each Water Train could make four round trips daily, bringing water from a source that was 600 miles away from its users. For shorter travel distances, even more round trips per day could be made. For example, at 300 miles distance, a Water Train could deliver 80 million gallons of water daily, enough for millions of users.

Energy consumption of the Water Train is minimized by three design changes, which distinguish it from the single Maglev-2000 vehicle proposed for passenger and freight transport. First, by joining the Maglev vehicles into a long, streamlined unit train, the air drag per vehicle is greatly reduced, by a factor of 4, compared to an individual vehicle. Second, collapsing the empty bladders for the return trip reduces air drag by another factor of 2, compared to the drag for full bladders during the delivery trip. Third, placing iron plates on top of the narrow-beam guideway generates a strong upwards attractive force on the superconducting magnets that acts to levitate the vehicle. This "iron lift" levitation force has virtually zero magnetic drag losses. The aluminum loops on the guideway now provide vertical and lateral restoring forces around the equilibrium suspension point, rather than levitation. The electric power losses in the aluminum loops (which are given by the product of the square of the loop current multiplied by the electrical resistance of the loop), still generate some small amount of magnetic drag on the Maglev vehicles, but because their time-averaged currents are much less than when they provided the levitation force, the magnetic drag effects are much less.

Delivery by the Water Train is much cheaper and more adaptable to terrain changes than by pipeline. For every 300-foot increase in elevation of a pipeline, for example, water pressure decreases by 150 psi; if elevation decreases by 300 feet, water pressure increases by 150 psi. If there are major changes in elevation, pipelines have to either build bridges or drill tunnels—depending on whether the change is downhill or uphill—or change water pressure using turbines or pumps. In either case, the process is very expensive.

Because of its high speed, the Water Train can follow the rise and fall in terrain with virtually no penalty. On upgrades, the Train slows slightly as kinetic energy is transferred to gravitational energy; on downgrades, the train speeds up slightly as gravitational energy is transferred to kinetic energy. At 200 mph, the Water Train can easily negotiate a 300-foot change in elevation, with a speed change of only 20 mph.

The cost of delivery by Water Train is proportional to distance. Taking into account the amortized cost of the on-grade guideway and the vehicles, plus the energy and other operating costs, the total cost for delivering 1,000 gallons of water over a distance of 600 miles is approximately one dollar. In comparison, just the amortized cost (not including operating costs) for

**FIGURE 5**  
**Artist's Depiction of the Water Train System**

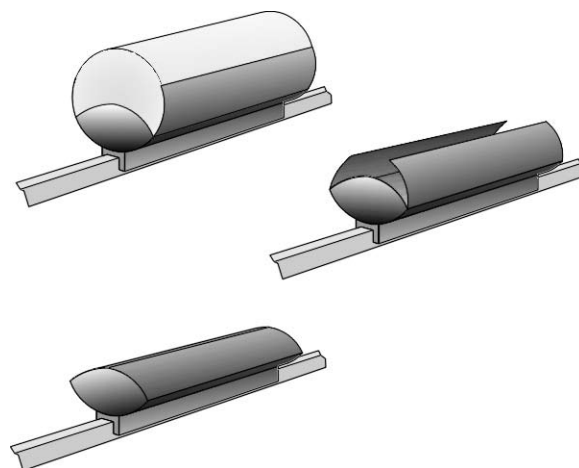

*Each Water Train vehicle has a bladder that holds 50,000 gallons of water. Thus a 200-vehicle unit train could deliver 10 million gallons per trip. A Water Train vehicle with bladder filled is shown at top. For the return trip, the bladders would be collapsed (bottom), in order to reduce air drag.*

the approximately 600-mile pipeline in Libya—which cost more than \$30 billion to build and delivers 600 million gallons daily—is on the order of \$5 per thousand gallons.

There are many potential routes for Water Trains. In the United States, billions of gallons per day of water could be transported from the Lower Columbia river to California, Nevada, and the rest of the Southwest. In the High Plains region, water could be brought from the Mississippi and Missouri Rivers to Colorado, Texas, Nebraska, and other drought areas. In the Mideast, Turkey has a large water surplus, some of which could help Iraq, Israel, Saudi Arabia, Syria, and other water-short countries in the region.

China has large areas where water is very short, and is considering a \$60 billion canal system to help alleviate shortages. The proposed canal has raised serious concerns about pollution effects, however. The Water Train eliminates these concerns. There are many other areas in Asia and Africa to which the Water Train could bring much needed water.

Finally, in contrast to pipelines, whose only function is to deliver water, using the Water Train, the same guideway that carries the water-bearing vehicles can also carry passenger and freight vehicles, providing efficient, low-cost, high-speed transport to help raise living standards, as well as bringing the water needed for life itself. The very high transport capacity of Maglev enables this dual usage capability.

## Getting Maglev Moving

In our view, it is inevitable that Maglev will grow and evolve into the major mode of transport in the 21st Century.



The benefits that it offers—greater speed, no need for oil, zero pollution, reduced cost for passenger and freight transport, and absence of congestion, will draw more and more users to it.

The real question is, how soon can Maglev make a major impact on transport, and what can be done to speed up the process? Maglev technology is already here. No fundamental new materials or inventions are needed. Rather, Maglev needs operating experience and testing on revenue routes, and engineering development and optimization to lower the construction and operating costs. Governments, particularly in Japan and Germany, have played a key role in developing Maglev, with each spending about \$2 billion. However, their first-generation systems are too expensive and constrained in scope to be widely implemented. We need second-generation Maglev systems, like that of Maglev-2000, which have a lower capital cost and serve a wider market, such as the transport of truck-type freight.

Although reducing the cost of Maglev systems and broadening their capabilities is necessary, it is not sufficient. Government leadership is also needed to make Maglev happen. Ensuring efficient, effective, and affordable transport is a fundamental duty for government. In the past, the U.S. government has always played a major role in vigorously planning for, and implementing, new and better modes of transport. The rapid westward expansion and industrialization of the United States in the last half of the 1800s, was a result of the massive land grants and subsidies to railroads from the government. Similarly, the U.S. Interstate Highway system, on which our material prosperity strongly depends, came into being because the government planned and funded it. Our quality of life would be much poorer without air travel, which enables the rapid movement of people and goods within the United States, as well as globally, but it also would not have happened without massive government funding of airplane development and airport construction.

Governments can help bring about second-generation systems by funding demonstrations of advances in Maglev technology, and by entering into public-private partnerships to build revenue Maglev systems. In this latter role, government should not subsidize systems that are economically non-viable. Instead, government should offer funding incentives to bring about improved, lower-cost Maglev systems that will attract users. For example, the government's contribution to guideway cost could be structured so that as total cost decreases, the government's contribution would increase. This would be a powerful incentive for engineering improvements that actually lowered cost, rather than a straight subsidy to help prop up an uneconomical system.

It is critically important that governments recognize that developing new, more efficient transport systems like Maglev, which do not need oil, should be a major near-term goal. Oil should be reserved for use as a chemical feedstock. Those countries, like Japan, Germany, and China, which have already started to implement Maglev systems, have the potential to become the world's leaders in this new mode of trans-

port. Maglev will yield enormous benefits, not only from its much lower costs for moving people and goods, and its reduced requirements for expensive energy, but also from the hundreds of thousands of new jobs that it will create. Many of these new jobs will be in companies that manufacture Maglev vehicles and guideways for export to other countries.

Maglev is a transforming technology for transport, as important in its impact as the introduction of ships, railroads, autos and trucks, and airplanes. Just as they transformed humanity's ability for rapid and efficient transport of people and goods, with a corresponding improvement in living standards, so will Maglev.

## References

1. J.R. Powell and G.T. Danby, 1966. "High Speed Transport by Magnetically Suspended Trains," Paper 66-WA/RR-5, ASME meeting, N.Y., N.Y. Also, "A 300 mph Magnetically Suspended Train, *Mechanical Engineering*, Vol. 89, pp. 30-35.
- Further details on the technology and applications of Maglev can be found at [www.maglev2000.com](http://www.maglev2000.com).
2. *The Eurasian Land Bridge—the New Silk Road—Locomotive for Worldwide Economic Development*, by J. Tennenbaum, et al, Executive Intelligence Review (January 1997).
3. A Maglev "Ring Rail" around the top end of Australia, between Melbourne and Perth, is discussed in "The Infrastructure Road to Recovery," Feb. 2002, published by the Citizens Electoral Council of Australia.

## About the Authors

*Dr. James Powell and Dr. Gordon Danby invented superconducting Maglev in 1966, and were granted the first patent in the field. Their original Maglev design is now operating in Japan.*

*Dr. Powell was a Senior Scientist at Brookhaven National Laboratory, where he directed research on fission and fusion reactors, from 1956 until his retirement in 1996. He is the inventor of the compact ultra-lightweight Particle Bed Nuclear Rocket, which was the basis for the Department of Defense/Strategic Defense Initiative programs on Space Nuclear Thermal Propulsion in the 1980s-1990s. In addition to Maglev, he currently is involved with space nuclear propulsion and power systems for planetary exploration, as well as advanced low-cost methods for vitrifying high-level nuclear waste.*

*Dr. Danby was a Senior Scientist at Brookhaven National Laboratory, where he directed research on superconducting magnets and high-energy particle accelerators, from 1957 until his retirement in 1999. He is the inventor of aluminum-stabilized superconducting magnets, and a pioneer in the development of MRI systems—Magnetic Resonance Imagery—for medical diagnostics. In addition to Maglev, he is currently involved in the development of next-generation MRI scanners.*

*Powell and Danby were awarded the Franklin Medal for Engineering for their Maglev invention in April 2000 (previous recipients included Nikolai Tesla and Charles Steinmetz). Maglev-2000 of Florida is developing their advanced second-generation Maglev system to carry passengers and trailer trucks.*