

---

## What Exactly, Is a Human Being?

---

# Analog, Digital, and Transcendental

by Sky Shields, LaRouche Youth Movement

A review of the development of the human species—in particular, the radical steps forward taken during the period of Franklin Roosevelt’s economic recovery policies—provides us with a unique angle from which to approach the disease represented by the modern “post-human” hoaxes being pushed today. Rather than twirl ’round and ’round, attempting to parry every sophistry in the arguments underlying the cybernetics fraud, we ought to ask ourselves the obvious question: What, exactly, is a human being?

The reductionist’s argument on this point hangs on a single sophistry, which is the same sophistry he wields when asked the question, “What is life?” He proceeds to examine everything about the human being which is not characteristically human, and then to conclude from that, that the human being is simply a rather sophisticated animal. The silly reduction of the uniqueness of the human species to physiological differences such as cranial capacity, posture, physiology of the throat, or an opposable thumb, is an intentional evading of the issue. It is no less silly than trying to define life from the standpoint of organic chemistry or molecular biology: The reductionist reduces the living organism to its non-living parts, before asking what makes it alive. This is akin to attempting to understand the idea underlying a great poem by analyzing the letters of the alphabet used, and how they interact with one another. At this point in the dissection, the idea under consideration ceases to exist.

As we will see below, there is an infinitesimal—a unit building block—in language, but these are not the letters, any more than the fundamental elements of a living process are its atoms—at least not atoms as they are currently understood. Similarly, once you reduce the analysis of human activity to its animal functions, it is no longer possible to discuss what a human being actually is at all.

We will take the opposite approach, and view the human being as any great composition ought properly to be considered: as a coherent whole. Taking our cue from Plato in *The Republic*, we will examine the human individual as that which takes part in the organization of human economy.

Human economy—the progress of the development of the human species on the planet—is characterized by rapid and sudden upshifts in the rate of growth of the human population. These sudden upshifts correspond to periods of social reorganization, on the basis of scientific and technological progress, clearly corresponding to the 15th-Century Italian

Renaissance, for example. If the periods between these singular moments are recognized as “units” of human development, it can be seen that this type of constant, anti-entropic development of the human species depends entirely on the discovery and social implementation of new scientific and cultural ideas. That is, this type of characteristic growth, not seen in other species outside of objective changes in their environment, or physiological evolution, depends entirely on the creative powers of the human individual, expressed in the areas of both physical science and Classical artistic culture. The question thus becomes, whether this characteristic type of creative capability is replicable by any non-cognitive (abiotic, or even simply biotic) process. The answer, is that the human mind transcends such biotic and abiotic notions in the same way that a circle transcends an infinite polygon; and the human mind is no more composed of its living and non-living parts than a circle is composed of infinite straight lines. Jumps of the type which would normally be attributed to genetic shifts within an animal species, occurring on a timescale so large as to never have been directly observed to this day—changes in life-expectancy, resource usage, social organization, and the like—are, for humanity, compressed into the lifetimes of individual, creative human beings. The human individual, like the circle, is a single idea which is outside of, and guides and directs the parts which give it expression.

Exemplary of this characteristic of the human mind, is its ability to discover, and wield, new transcendental conceptions; conceptions which are defined solely by the fact that they transcend entirely—indefinitely—the logical systems which preceded them. The model for this transcendental relationship is found in Nicholas of Cusa’s quadrature of the circle.

A later transcendental relationship, discovered by Gottfried Leibniz, provides us with a unique window into the methods used during Franklin Roosevelt’s return to the principles of the American Revolution, and an insight into the methods by which such transcendental notions are incorporated into the development of human economy—in particular the work of American scientist Vannevar Bush (see box, in this section)—in extending the cognitive capabilities of mankind as a whole. The exponential curve, or its inverse, the logarithmic curve, is the curve constructed on the basis of constant, continuous, self-similar growth. Its familiar expression is found in the form of Leibniz collabo-

FIGURE 1

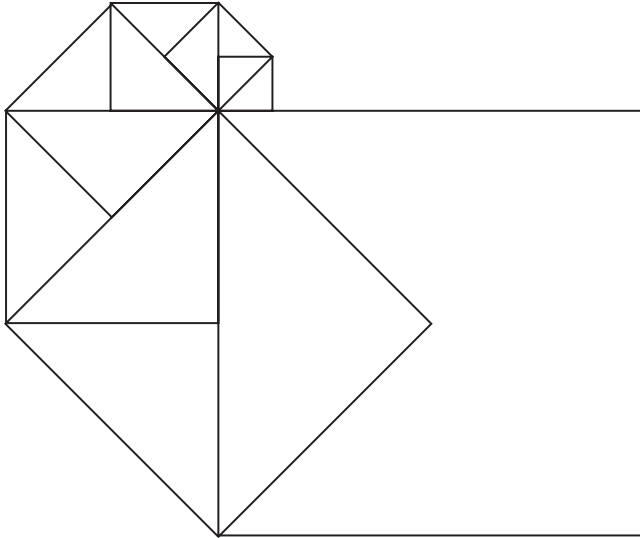

rator Johann Bernoulli's *Spiral Mirabilis*, or logarithmic spiral (Figure 1).

In the logarithmic spiral, equal, arithmetic angular divisions thus correspond to radial lengths increasing in geometric progression. The same thing can be expressed along a horizontal line, by simply producing a series of lines in geometric progression, spaced at equal intervals. In this case, the progression is:

$$1:2 :: 2:4 :: 4:8 :: 8:16 \dots \text{(Figure 2)}.$$

Obviously, in both of these cases, neither progression is actually a continuous curve. The question becomes: What continuous curve has this property of self-similar growth over every interval, and not merely at discrete steps? Let's begin by looking at any line connecting two discrete points on the curve, such as the ones we have just drawn (Figure 3). Here, the triangle *aAs* is similar to the triangle *AWT*—having the same angles. That is, we have the proportion:

$$as : As :: AT : WT.$$

Or, letting  $WT = k$ ;  $OT = x$ ;  $AT = y$ ;  $As = Tt = dx$ ; and  $as = dy$ :

$$dy:dx :: y:k$$

If the points *A* and *a* on the curve are adjacent, that is, if there is no distance between them, the line *AW* will be the tangent to the exponential curve at the point *A*. Also, since this curve was constructed using powers of 2, if  $OT = x$ ,  $AT = y$  will be  $2^x$ . Also, if  $Tt = dx$ ,  $at$  will be  $2^{x+dx}$ . Therefore our ratio becomes

$$(2^{x+dx} - 2^x) : dx :: 2^x : k$$

or, which is the same

$$2^x(2^{dx} - 1) : dx :: 2^x : k \text{ or } y(2^{dx} - 1) : dx :: y : k$$

FIGURE 2



FIGURE 3

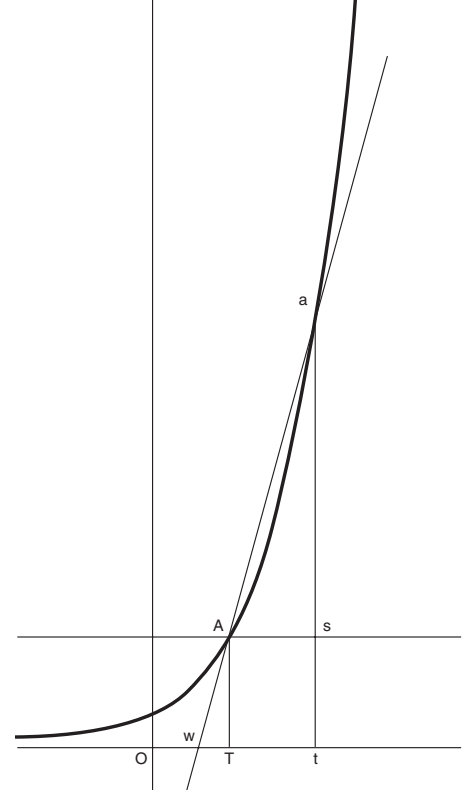

or

$$(2^{dx} - 1) : dx :: 1 : k$$

That is, if  $dx$  is taken as constant everywhere on the curve, the distance  $k$  will be a constant equal to

$$\frac{dx}{2^{dx} - 1}$$

“But,” you might object, “if the points are adjacent, both the ratios  $\frac{dy}{dx}$  and  $\frac{dx}{2^{dx} - 1}$  are equal to  $\frac{0}{0}$ .” But remember! This is simply an empiricist's object fixation. For the empiricist, as soon as all of the objects disappear, what is left must be equal to 0. But for the human being, who “is not of the flesh, but rather of the spirit,” and for whom objects are simply the shadows of principle, it is only after all of the objects disappear that we can see what that truth actually was which lay behind them all the while. The example Leibniz used in a letter to his friend Pierre Varignon, in defense of this idea, was to imagine the triangle *MmO*, in Figures 4-7.

There is a constant proportion between the sides of triangle, even as it becomes smaller and smaller, and regardless of which side of *O* the triangle is located on. But what happens at the moment the triangle is passing from one side to the other? At that moment, the sides become smaller than anything imaginable, but nothing has changed about the angles to destroy the proportion. Therefore, the sides have vanished, but the proportion still exists!

FIGURE 4

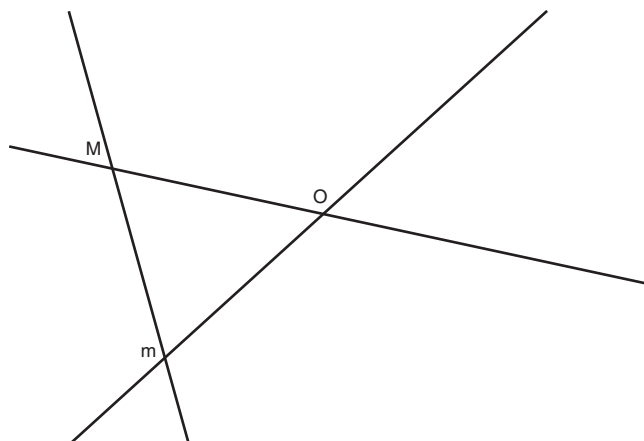

FIGURE 5

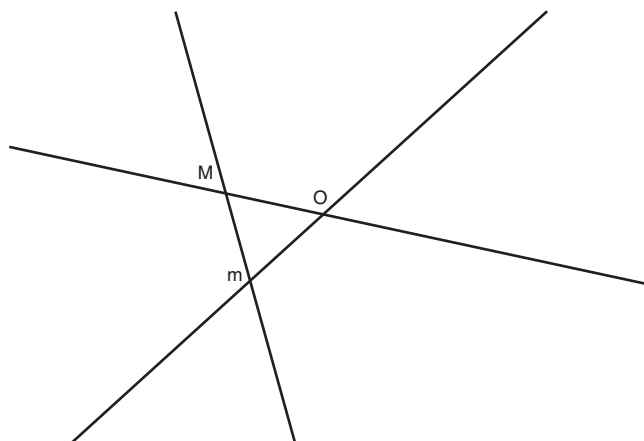

FIGURE 6

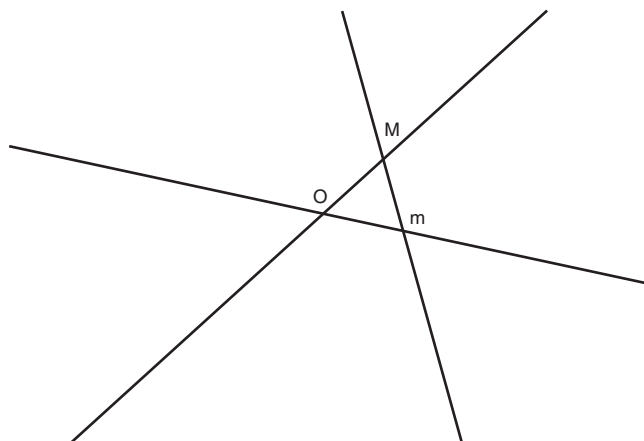
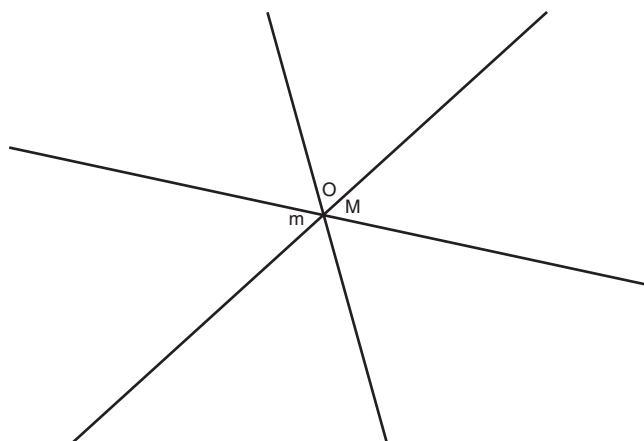

FIGURE 7



Put in somewhat simpler terms: If you have a sleeping dog, and the dog vanishes, you will no longer have a sleeping dog. If you have a running dog, and the dog vanishes, you no longer have a running dog. In neither case will you be left with “a running” or “a sleeping” for a pet. This does not mean, however, that there is no difference between a sleeping dog, a running dog, and a dog. But where, then, is the difference located? What do a running *dog*, a running *gazelle*, and a running *emu* have in common? If the noun vanishes, where is the verb? With respect to the noun, the verb is =0. However, no sane person would argue that verbs do not exist.

If you keep this in mind, you’ll easily find that the ratio given for  $k$  is exactly equal to the ratio of the height and base of the triangle where  $x$  is equal to zero.

### Speaking of Verbs

When Descartes banned transcendental geometric relationships from his mathematics, as something it could not comprehend, what he actually said was that “mechanical” curves would not be included. By “mechanical,” he meant

the various types of transcendental relationships investigated by the Greeks, which were embodied in physical, mechanical constructions, and which transcended the simple algebraic expression to which he, like a digital computer, was limited. These included the quadratrices of the various conic sections, the cycloid, and the catenary (Figures 8-9).

Calling these transcendental curves “mechanical” makes a significant point, whose significance was lost on Descartes himself: The construction of these curves constituted the first occurrence of what later came to be referred to as an “analog computer,” a reflection of one of the fundamental principles of human economic progress.

The principle involved here is one referred to often by economist Lyndon LaRouche as the “machine-tool principle.” That is, we have taken an essential, experimentally determined property of this type of constant, self-similar, geometric growth, and embodied it (incorporated it) whole, in a man-made, physical process. The principle already existed, as part of the “shape” of physical space-time. It is necessary, however, to reorganize the shape of man’s interface with that physical space time—the physical economy—to reflect that

FIGURE 8

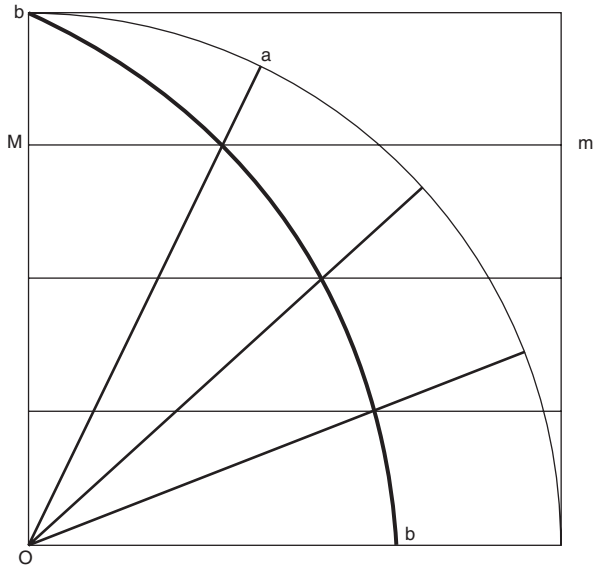

The quadratrix of the circle,  $ab$ , is the path produced by the moving intersection of a rotating rod,  $Oa$ , and a sliding bar,  $Mm$ , when both move at a constant rate.

FIGURE 9

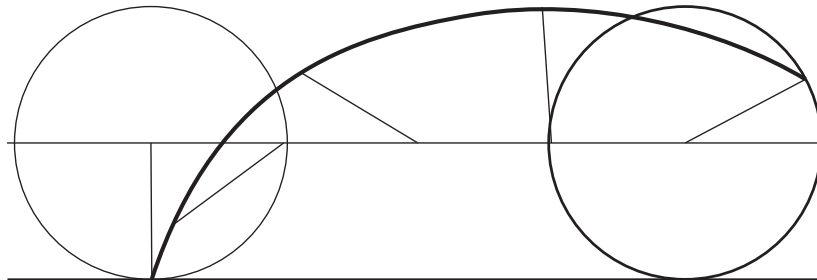

The cycloid is the curve produced by tracing the motion of a point on the surface of a rolling disk.

FIGURE 10

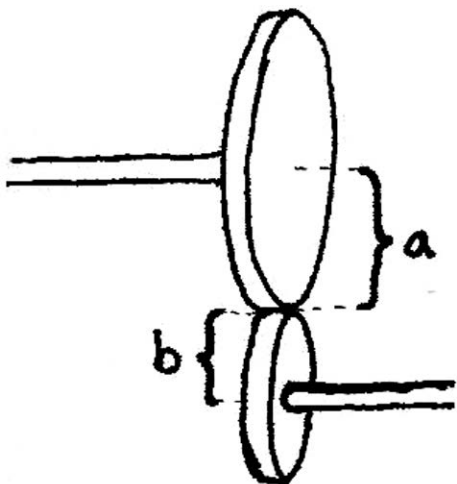
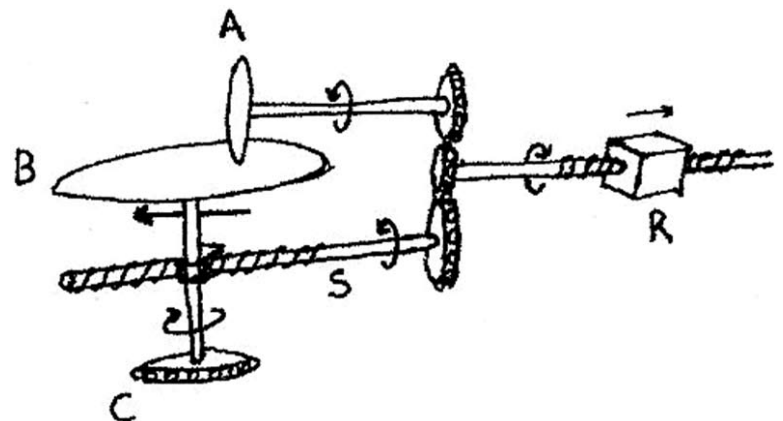

FIGURE 11



discovered form. The point of intersection of these two physical geometries—that of physical space-time, and that of the physical economy—is the machine-tool sector, where the possibility of implementation of a given discovered, physical principle, in a whole array of technology, is realized. Because the method of generating this type of implementation is by creating “analogous” processes in the physical economy, such that they reflect the underlying, invisible structure of physical space-time, such a method is called “analog.” This method is the characteristic form of human creative activity, and the basis for all human economic progress.

As chairman of the President’s National Defense Research Committee, and later director of the Office of Scientific Research and Development during the economic explosion generated by President Franklin Delano Roosevelt’s reforms, Dr. Vannevar Bush gained firsthand experience with this principle. His role in the 1940s fight against fascism—and its subsequent subversion by the twin revival of the menace of the Austro-Hungarian Empire, Norbert Wiener and John von Neumann—has been documented elsewhere. (See articles in this section.) Here, we will apply his method to a consideration of the exponential curve.

Picture two gears, transmitting motion from one to another (Figure 10). If the ratio of the two radii is  $a$  to  $b$ , then  $b$  rotations of gear A will correspond to a rotations of gear B. This means also that a tiny change in gear A—call it  $dA$ —will have the same ratio to tiny change,  $dB$ , in B, will be the same as  $a$  to  $b$ . This ratio of rates of change,  $dA/dB$ , is called the “gear ratio” of the two gears.

Therefore if, as in the device pictured, the two gears A and B can move relative to each other, their gear ratio is variable. If we let gear A =  $y$ , and gear B =  $x$ , that variable gear ratio will be equal to the ratio  $dy/dx$ . If that variable

gear ratio is governed by the motion of the gear  $y$ , transferred by means of a screw threading,  $S$ , our variable gear ratio becomes equal to the horizontal displacement of that screw threading, which will be equal to the rotation  $y$ . If the rotation at  $C$  of  $x$  is maintained constant, we will have the relationship  $dy/dx = y$  expressed by our exponential curve above.

If now (Figures 11-12), that same motion  $y$  is transmitted to a carriage,  $R$ , by means of another screw threading, and the same constant motion,  $x$ , which drives the gear  $B$  at  $C$  is attached to another carriage, riding on the carriage  $R$ , but moving vertically, we will obtain the curve produced by the horizontal motion  $y$ , and vertical motion  $x$ , such that  $dy/dx = y$ . That is to say, we will have our desired exponential curve, for the case where the distance  $k$  is equal to one. The reader is left to devise means to determine the remaining cases.

### Squaring the Circle, Again (And Again and Again and Again...)

So now, what relationship, if any, does a digital computer have to that process? To begin with, we'll have to figure out how to communicate that type of transcendental relationship to a digital computer, in terms of the basic logical operations of addition and subtraction which it is capable of understanding. If it is desired to draw the curve itself, we must figure out how to translate the process given above into the types of algebraic relationships our poor digital computer can comprehend.

Since it is not possible to discuss any actually continuous process with our computer, we will have to talk to it in terms of points. We know that our curve  $y = e^x$  is equal to 1 at the point where  $x = 0$ . The simplest algebraic equation with this property is

$$y = 1$$

but, since we also know that

FIGURE 12

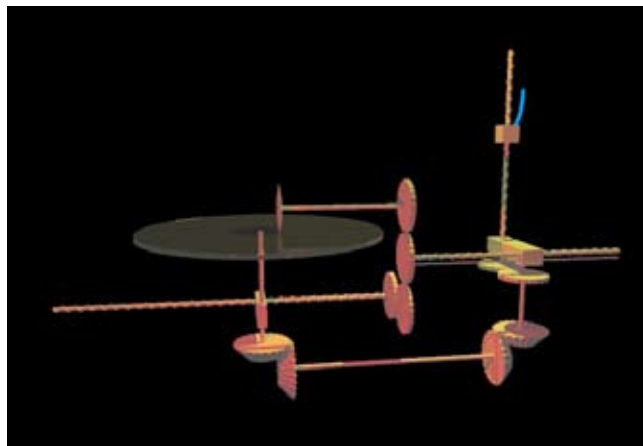

Carriage mechanism designed by Daniel Yule of the LaRouche Youth Movement. Animation is at <http://tinyurl.com/37qv51>.

$$y = \frac{dy}{dx}$$

and thus  $dy/dx$  is also equal to one at the point  $x = 0$ , we have to pick a more complicated algebraic equation

$$y = 1 + \frac{x^2}{2}$$

which is still equal to 1 where  $x = 0$ , but for which  $dy/dx$  is also always equal to 1. However, since, again,  $dy/dx = y$ , we have to find a curve for which

$$\frac{dy}{dx} = 1 + \frac{x^2}{2},$$

or

$$y = 1 + \frac{x^2}{2} + \frac{x^3}{2 \cdot 3}.$$

Hopefully, you can already see that the process of trying to fit this round peg into a square whole will continue forever, giving us

$$y = 1 + \frac{x^2}{2} + \frac{x^3}{2 \cdot 3} + \frac{x^4}{2 \cdot 3 \cdot 4} + \frac{x^5}{2 \cdot 3 \cdot 4 \cdot 5} + \dots$$

which will never become equal to  $e^x$ —though, if you have something dumb enough but fast enough—like a digital computer—it will eventually produce something that bears the same relationship to our curve as the multi-sided polygon bears to the circle.<sup>1</sup>

So then, is it possible that the type of transcendental activity expressed by the human mind—and which drives the anti-entropic growth of a human economy—could ever be replicated by a digital process? After all, it could be argued that a many-sided polygon really does make a passably good circle, can't it?

The sophistry here, is that without having a circle to begin with, there would be nothing for the many-sided polygon to imitate in the first place! The circle is an elementary unit—a monad in the sense of Leibniz. It is generated as a single idea, by a single simple process of circular action. In that sense it, like the human personality, has no parts. It is a one—a whole. Therefore, from the standpoint of the polygon, the circle is actually infinitely far away. This type of transcendental relationship is the same as that which holds between human activity, and that lower behavior of the animals. It is also the same sort of infinite gap which lies between the living and the non-living. The human individual must be regarded as a single, living, cognitive whole, and not merely as the “sum of his parts” because, in reality, he has none.

1. This process is often inappropriately called the “Taylor” expansion, though it was earlier discovered by both Gottfried Leibniz and Johann Bernoulli.