The Secrets of Economy

REPORT

The Promise of Fusion Rocketry

by Joel DeJean

This is a transcription of the oral report given by Joel DeJean to a LaRouche PAC class in Houston on June 24. He was introduced by Kesha Rogers of the LaRouche PAC Policy Committee, who noted that the subject is not simply the technology of fusion power, but the development of fusion power as a way to ignite the advance of mankind. Extraordinary developments are taking place, she said, and DeJean's report has implications beyond

science as such. Right now we need to make a total scientific breakthrough for mankind. There are new developments in research that will take the American-Chinese cooperation for the New Silk Road to the next leap. That is what fusion power and cooperation in space will do, because we're not just talking about the Chinese coming here to help us build our railways systems and rebuild some dams and ports, and then going home.

FIGURE 1

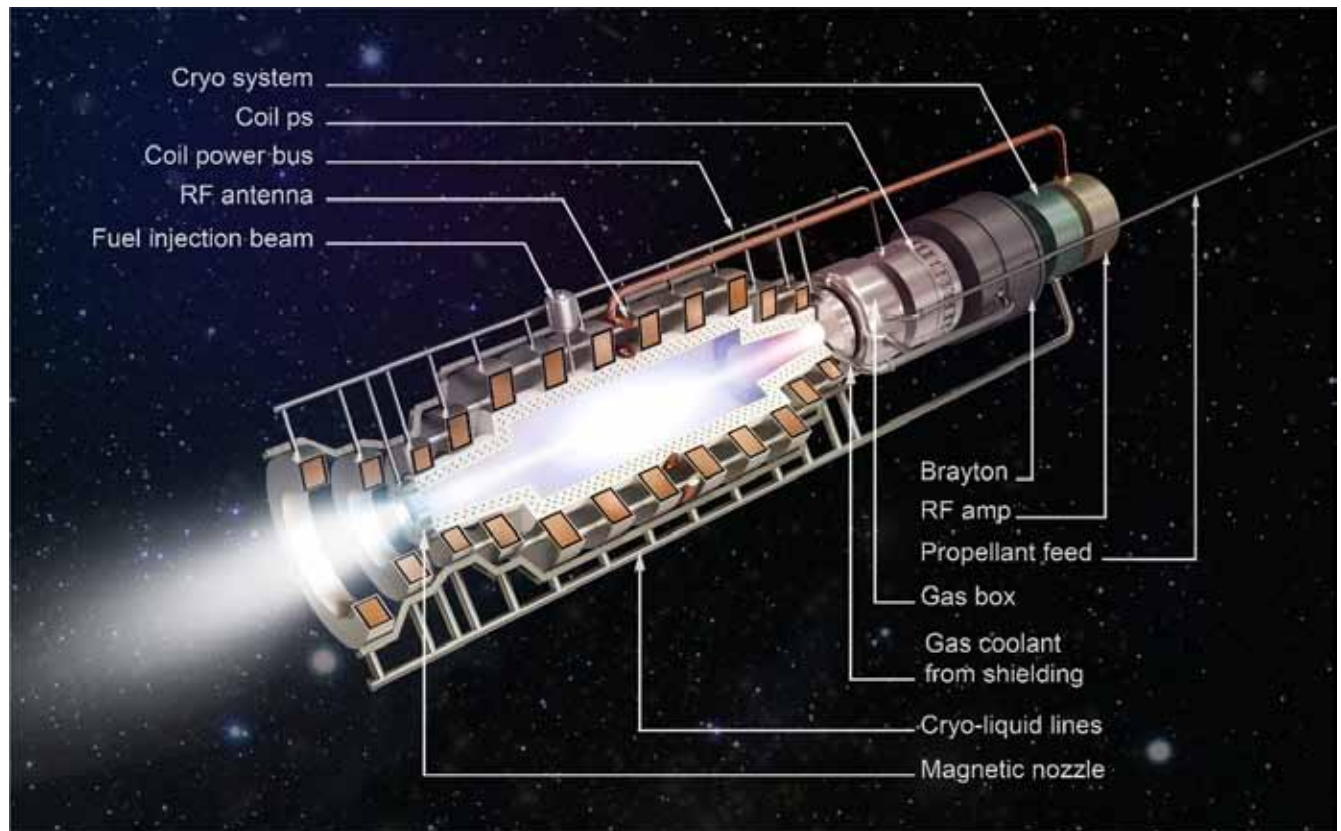

Artist's rendering of a Direct Fusion Drive engine with interior cutout to show detail of the magnetic coils.

Rather, we must ask, “What is the next mission of cooperation for mankind?” And the answer, she said, is space cooperation, and space cooperation driven by the development of fusion power as the key source for increasing the energy available to mankind.

A few weeks ago we had a conference call on the Space Silk Road, and discussed some of the latest developments on how to get to low Earth orbit. Additionally, Brian Lantz discussed some of the developments around nuclear thermal rockets—fission-based rockets that will be useful to go between low Earth orbit and the Moon. Then Kesha sent me the link to an article about a recent design for a fusion rocket to go to Mars, a rocket with an engine about the size of a refrigerator, and Megan Beets found another article about it. I called Michael Paluszek, the president of Princeton Satellite Systems, which developed this proposal a few years ago, and he sent me the proposal itself. His team proposes a manned mission to Mars, using what it calls a Direct Fusion Drive rocket engine. It could accomplish a round trip in something like 310 days.

Before I get to the proposal, I’m sure you all remember that *Curiosity*, which is still functioning on Mars, left Earth orbit on Nov. 26, 2011, using a chemical rocket, and landed on Mars on Aug. 6, 2012. So it took more than eight months to get from Earth to Mars—eight months! During its voyage, the team got readings from sensors measuring the amount of cosmic radiation that would hit a traveller en route to Mars for nine months. It turned out that it would be something like the equivalent one CT scan a week for a whole year. Combine that with the low-gravity atrophy of your muscles, living at microgravity for months. If you were to send a crew to Mars using chemical rockets, you would probably end up with a dead crew, before they even got to Mars orbit. At the least, by the time they got to Mars orbit they certainly wouldn’t be very functional.

What piqued my interest in the design of the Direct Fusion Drive, was not only that it was using compact magnetic confinement, but that it was also using the combination of deuterium and helium-3 as its fuel.

Why fusion? Why not use more efficient chemical rockets? Or why not use nuclear thermal rockets, in which a fission core heats a gas, and that gas is used as the propellant? Well, the most efficient chemical propellant rocket that we have, uses the reaction of hydrogen gas with oxygen, $H_2 + O_2$, to get H_2O , or water.

This reaction releases 8 electron volts of energy. Now fusion is what happens in the Sun—and we’ve already achieved fusion on Earth, called the H-bomb; what we are seeking is controlled fusion, so that you can control the release of the energy. In this case, we use an isotope of hydrogen called deuterium, which has one proton and one neutron, instead of having just one proton. With it, we use an isotope of helium, called helium-3. Normal helium is helium-4, which has two protons and two neutrons, but helium-3 has two protons and only one neutron. We want to fuse those two atoms.

To fuse them, we need high temperatures, and we need a certain density of what is called the plasma—and we’ll go through that—and we need enough time under these conditions so that you can have these elements fuse, creating a new element—helium-4 plus a proton. The energy released from this fusion reaction, called the D-He3 or deuterium-helium-3 reaction, is 18 million electron volts. So in the chemical and fusion reactions, you have only the elements of hydrogen, helium, and oxygen—an isotope of hydrogen, or a molecule of hydrogen, an isotope of helium, or a molecule of oxygen—but the fusion process releases more than a million times more energy in electron volts, a million times more energy than any chemical reaction, whether it’s combustion, the process inside an electric battery, or whatever.

Now I want to go through the concept of this rocket design. The Direct Fusion Drive engine is based on developments at Princeton University. The Princeton Plasma Physics Laboratory (PPPL) has been working on fusion for decades, even though it has had major setbacks in funding. PPPL is using the concept of magnetic confinement of the plasma to get fusion.

Princeton Satellite Systems’ idea is to use its Direct Fusion Drive engine together with NASA’s Space Launch System, and with NASA’s Orion spacecraft carrying the crew as far as Earth orbit. (Orion is now being developed.) You will launch this ensemble to Earth orbit to reach the Deep Space Habitat, a module now being developed by NASA for living and working, which will travel between Earth orbit and Mars orbit. The motor in this concept is six of the Direct Fusion Drive rocket engines. You launch the Deep Space Habitat into Earth orbit with the Space Launch System, which has about the lift capacity of the old Saturn V. The Saturn V rocket from the Apollo Program days

FIGURE 2

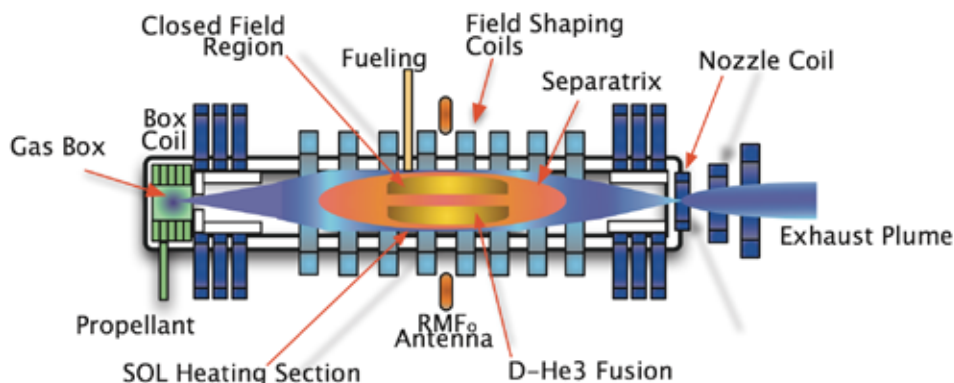

Schematic of Direct Fusion Drive core. Deuterium gas, introduced into the gas box, is ionized there. This newly formed plasma flows to the right in the scrape-off layer (SOL), where the electrons are heated as they pass over the field-reversed configuration region.

could lift 100 metric tons of payload into low Earth orbit, if you remember, which included the capsule, the landers, all the equipment, and the crew.

So what you do now is, first, launch that Deep Space Habitat with the fusion motor into Earth orbit. Then, after everything has tested out in orbit, you launch the crew into the same Earth orbit in the Orion capsule, for transfer to the Deep Space Habitat. Finally, the Direct Fusion Drive engines power the Deep Space Habitat to leave Earth orbit and head to Mars (see **Figure 1**).

To get to low Earth orbit, you have to reach a speed of 17,500 mph. So if you use your app and locate the space station—you can actually see it going over at night—it’s travelling at 17,500 mph to stay in orbit. Now, to leave Earth orbit you have to reach a speed of 25,000 mph, so that you can escape Earth’s gravity—to go to the Moon, Mars, or Pluto. What’s fascinating about the Direct Fusion Drive, shown in **Figure 2**—you see the exhaust on the right—is that it uses the Princeton Field-Reversed Configuration to confine the plasma.

Let’s review what a plasma is. If we start with a gas, like the air in this room, at high enough temperatures, the electrons orbiting hydrogen or oxygen or any atom, will be stripped away, so we will have ions and electrons separated from each other—and that’s called a high-temperature plasma.

The Direct Fusion Drive system uses deuterium, which is a heavy isotope of hydrogen (having an extra neutron), tanks of liquid deuterium, and liquid helium-

3, which is injected into the plasma chamber.

You may have seen the huge magnetic confinement systems that use a tokamak—a doughnut-shaped or torus-shaped vessel that has magnets going around its circumference (along the tube of the torus) and also at right angles (wrapping around the tube of the torus)—and when the magnets are in operation, they will confine the plasma, keeping it away from the inner walls of the torus.

Now to attain fusion, the plasma has to reach temperatures of close to 100 million

degrees Centigrade. You can imagine if you had plasma at 100 million degrees hitting the side of a vessel, made of any metal, it would vaporize that metal. So you contain it with magnetic fields.

The Princeton Field-Reversed Configuration uses—instead of a torus—a cylinder, with high-temperature magnets. When the helium-3 and deuterium gases are injected into the chamber, they are heated to the point of ionization with radio waves in the megahertz range, creating a plasma. The plasma, because it has charged ions and electrons, will create an electric field. And electric fields always create magnetic fields. The field created here will be the reverse of the *applied* magnetic field, and this will provide the containment. That allows us to have the plasma contained within about a 2 meter diameter inside that cylinder. So the dimensions are 2 meters in diameter and 10 meters long.

Once you ionize the gas, then you heat it further, to high enough temperatures to achieve fusion. Now once you achieve fusion, because the reaction products, helium-4 and the proton, are positively charged, they can be manipulated using magnetic fields in what’s called a magnetic nozzle. If you look at the Space Shuttle when it launches, you see the nozzle directing the propellant—you can see the swivelling of the nozzles. But if you were to use an ordinary nozzle with high-temperature plasmas, you would melt the nozzle. So you have magnetic fields in the nozzle so that you can direct the exhaust.

FIGURE 3

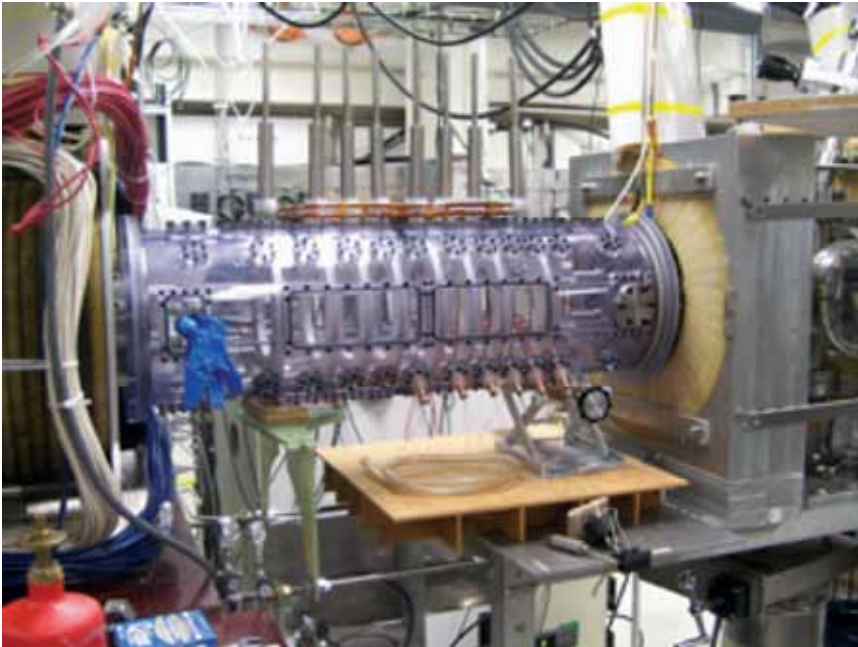

PFRC-2 device under assembly.

FIGURE 4



PFRC-2 device during operation.

In a chemical reaction, the exhaust velocity of the propellant is on the order of 10 kilometers per second, while in a fusion reaction you can get exhaust velocities of over 25,000 km per second or even higher, because of the high energy of a fusion reaction. You can adjust the exhaust velocity. You can get an increase in thrust through an increase in propellant velocity. This Direct

Fusion Drive will not only produce the exhaust from the propellant, giving you the thrust to get to Mars, but it will also generate electric power, to power the entire spacecraft for your mission to Mars.

Let's go back to Figure 2. The white areas in the figure are shielding. In another reaction that is typical for fusion experiments, deuterium and tritium are used instead of deuterium and helium-3—tritium being another isotope of hydrogen that has one proton and two neutrons. Using deuterium and tritium produces almost as much energy as deuterium and helium-3. However, most of the energy is carried off by a neutral particle, the neutron, which cannot be controlled by magnetic fields because it has no charge. The neutrons will hit the sides of the engine and will even penetrate the crew compartment, so you have to provide enough shielding to protect the crew from these high-energy neutrons.

But some shielding is needed even for deuterium-helium-3 fusion. Even though this reaction produces only positive charges, deuterium-deuterium reactions will also occur. While 95% of the fusion products will be charged helium-4 or a proton, about 5% will be high-energy neutrons and some tritium, so that you still need to have some neutron-shielding while the fusion process is going on.

Figure 3 shows the Princeton Field-Reversed Configuration as embodied in the PFRC-2 device while it was being assembled. They have already built this. They haven't achieved full fusion power yet, but this work is being done under NASA contract through the NASA Innovative Advanced Concept Program, which is intended to fund projects that could pay off in 10 to 100 years in the future.

Figure 4 shows the PFRC-2 device during experimental operation.

FIGURE 5

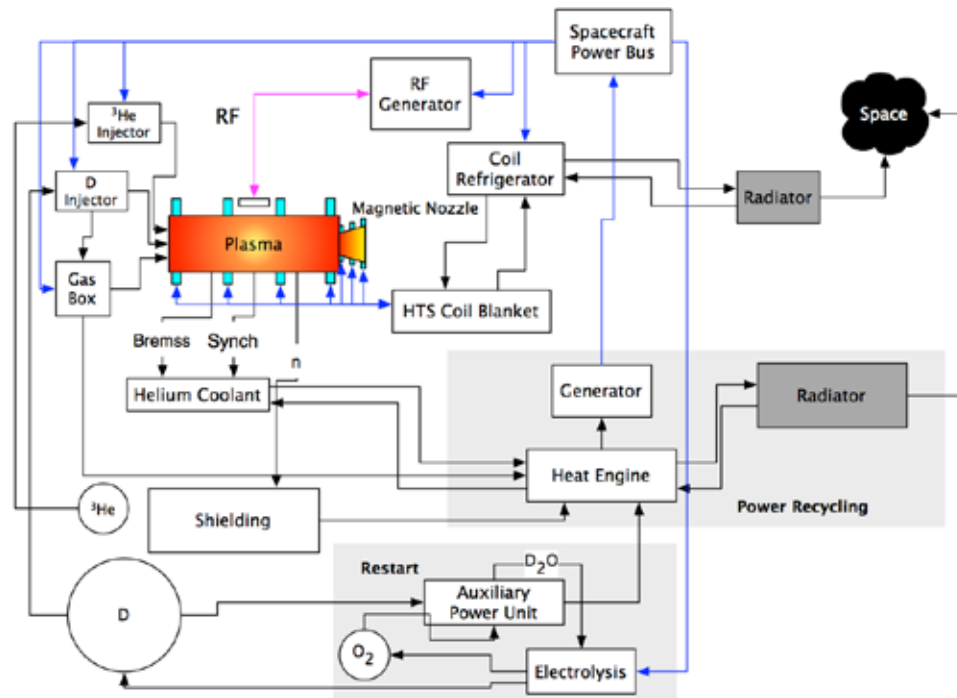

Direct Fusion Drive subsystems.

When I talked to Dr. Paluszek, he said that he and his team are ready for Phase 3, but they lack funding. Now, a measly 20 million bucks—we’re talking about a few cruise missiles, we’re talking about one-tenth of a F-35 fighter—would pay for the next phase. And they

FIGURE 6

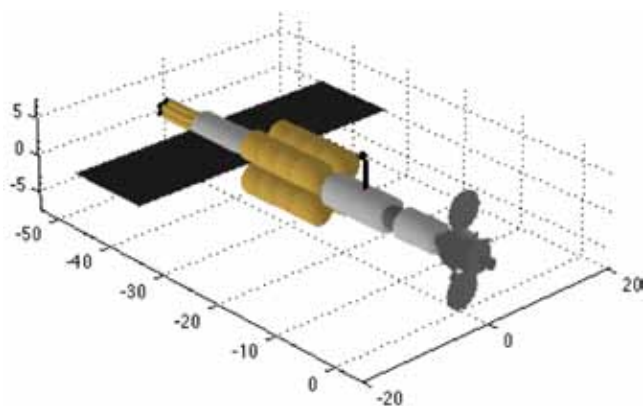

The Mars transfer vehicle with a docked Orion spacecraft on the far right. Next to the Orion are two high-gain dish antennas and then the Deep Space Habitat—two gray tubular units. The clustered, large brown tanks hold deuterium. The bundled Direct Fusion Drive engines are at the far end (shown in brown), beyond the heat dissipation panels.

project that once they prove that they can heat the plasma to high enough temperatures, and that it is dense enough, and that they can have long enough confinement time so that they can achieve fusion—then they can use these engines for a demonstration flight to Mars.

Figure 5 takes us beyond the plasma chamber. Here we see the subsystems necessary to make things happen in the chamber.

A lot of testing is required to prove the concept of the field-reversed configuration. The concept goes back to testing in the Los Alamos National Laboratory in the 1990s. It has also been tested in the Pacific Northwest National Laboratory in Redmond, Washington and the

U.S. Naval Laboratory in San Diego. Some testing has also been done at the Air Force Research Laboratory in Dayton, Ohio. So there’s a lot of research going on. Lockheed Martin is working on a compact magnetic fusion reactor that would be about the size of a truck. So, if they can divert some of that money from that F-35 program into fusion, we can get there a lot quicker. [laughter]

The Mars transfer vehicle, shown in **Figure 6**, consists of the the Direct Fusion Drive and Deep Space Habitat, where the crew of either four or six will live and work. The Deep Space Habitat, as you can see in **Figure 7**, is like a small space station. It has laboratory

FIGURE 7

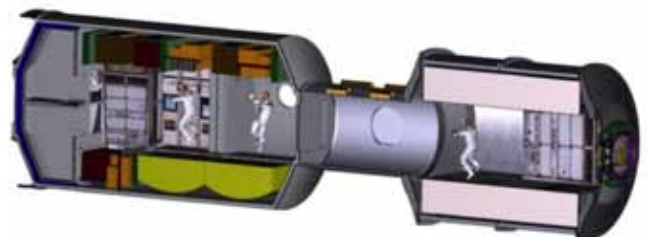

NASA’s Deep Space Habitat.

FIGURE 8

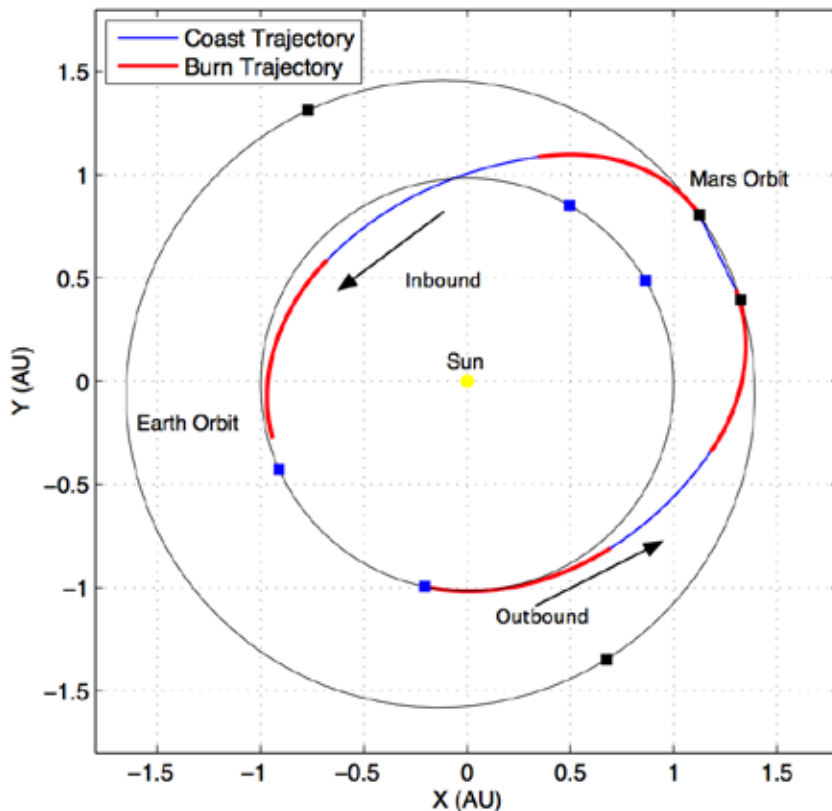

A round trip mission to Mars takes only 310 days, including 30 days in Mars orbit. The outer orbit is that of Mars.

and experimental compartments, as well as exercise rooms, so you can live in that habitat.

A round trip mission to Mars will take only 310 days, including 30 days in Mars orbit (see **Figure 8**). The Deep Space Habitat is driven by six Direct Fusion Drive rocket engines. Each engine produces 11.5 megawatts of power, so the whole assembly will produce about 70 megawatts, which is the power of the heavy nuclear-powered aircraft carriers such as the *USS Nimitz*.

When the crew is on board in Earth orbit, and everything tests out, the engines will burn to leave Earth orbit, followed by a coasting period, so the travel time would be about 140 days. That's still a little long, but this is the first step. Remember that the Wright brothers' first aircraft flew at about 40 mph. Now we go a little faster, but this is the first step.

The craft will achieve escape velocity and continue

to burn and then coast for a while. When it approaches Mars, the crew will have to turn on the motors to brake. The idea is to orbit Mars, not to fly by. So it will brake, achieve an orbital insertion, and then stay in Mars orbit for 30 days. To return to Earth, they will again fire the motors, achieve escape velocity from Mars orbit, and coast a while. Once they approach Earth, they have to slow down and enter Earth's orbit. At that point, another Orion capsule will be sent to Earth orbit to bring the crew back, because you won't come back to Earth's surface with the Deep Space Habitat.

Something like this would be the equivalent of Apollo 8. If you remember December 1968—the first time man left Earth's orbit was in December 1968. And if you remember, when the crew in the Apollo 8 approached the Moon, it was not immediately known whether they were down. NASA had to make precise calculations. In the movie, *Hidden Figures*, you see them doing the calculations. Because you have a moving capsule, you have the speed

in orbit—so everything had to be worked out to the *decimal point*. They went around the Moon, and of course you can't hear any radio signals once they're behind the Moon, and so there was a period of *minutes* when you didn't know whether they would make it, or they would go into the Sun, or what. And then they came back, and you heard them reciting from Genesis—it was Christmas Eve.

So this Mars orbital mission would be the equivalent breakthrough.

At the end of the paper, the authors mention that you could also use these Direct Fusion Drive rockets to deflect an asteroid coming at you. You could get to an asteroid and deflect it before it hits the Earth.

They also mention that Direct Fusion Drive could be used for robotic missions, such as a mission to Pluto. The recent Horizon mission to Pluto took nine years to get to Pluto, they say, but it didn't have enough fuel left

FIGURE 9

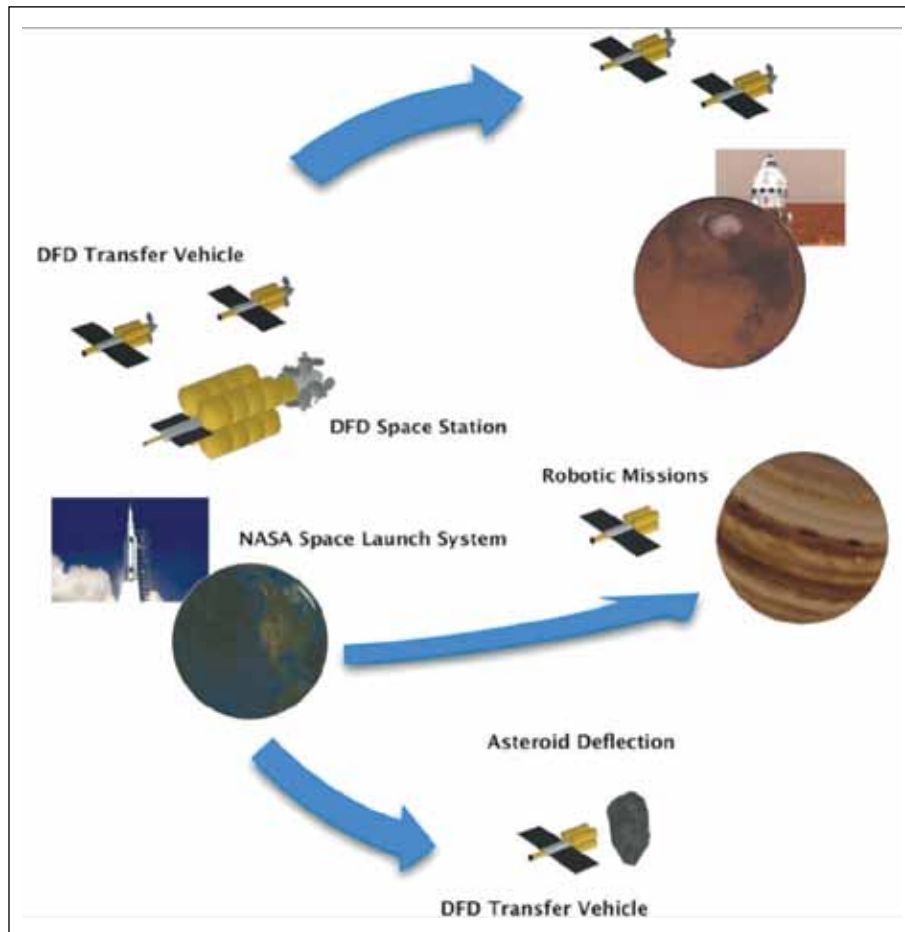

Direct Fusion Drive will open space to new avenues of exploration and rapid industrialization.

to brake, so it flew by Pluto in a matter of hours, meanwhile taking an abundance of pictures. The spacecraft had a very limited supply of power. Even though it was powered by a plutonium radioisotope thermoelectric generator, it had only about 200 watts of power, so that when it started transmitting the pictures back to Earth, the transmission rate was about 1,000 bits per second. So I think they're still transmitting pictures from Horizon! [laughter]

But with Direct Fusion Drive, you would have not only more thrust, but more electric power, something like 2 megawatts available for radio and other systems. So that an equivalent mission to Pluto would take something like four years instead of nine, and once you got there you could slow down and actually orbit the planet. Your transmission rate would be in the megabit

region, so that much more data would be transmitted back to Earth.

You would actually have enough power to send a lander to the planet, and you could beam energy to the lander with a laser system, so that it could actually move around the planet, even though it is billions of miles from Earth, where you can't use solar power.

What this example illustrates is that "Direct Fusion Drive will open space to new avenues of exploration and rapid industrialization," as the authors themselves say.

So this proposal is sitting on somebody's desk at NASA, and it was put together a few years ago. By the way, I did ask Dr. Paluszek whether he knows of any work being done by the Chinese. He said he can't talk to the Chinese. Because it's a NASA-funded program, it would be illegal for him to talk to the Chinese—and he can't even talk to the Russians! Even though, if we want to go to the Space Station, the only way to get there is with Putin's okay!

[laughter] ... So apart from money, what we need is more collusion.

References

Michael Paluszek et al., "Direct Fusion Drive for a Human Mars Orbital Mission," August 2014. PPPL-5064. Prepared for the U.S. Department of Energy under Contract DE-AC02-09CH11466. <https://www.osti.gov/scitech/servlets/purl/1182281>

Ryan Whitwam, "NASA-Funded Startup to Build Fusion-Powered Rockets," June 13, 2017. <https://www.extremetech.com/extreme/250836-nasa-funded-startup-aims-build-fusion-powered-rockets>

Stephanie Thomas, "Fusion-Enabled Pluto Orbiter and Lander," April 7, 2016. <https://www.nasa.gov/feature/fusion-enabled-pluto-orbiter-and-lander>

Every Day Counts In Today's Showdown To Save Civilization

NEW
REDUCED
PRICE!

That's why you need EIR's **Daily Alert Service**, a strategic overview compiled with the input of Lyndon LaRouche, and delivered to your email 5 days a week.

The election of Donald Trump to the Presidency of the United States has launched a new global era whose character has yet to be determined. The Obama-Clinton drive toward confrontation with Russia has been disrupted--but what will come next?

Over the next weeks and months there will be a pitched battle to determine the course of the Trump Administration. Will it pursue policies of cooperation with Russia and China in the New Silk Road, as the President-Elect has given some signs of? Will it follow through against Wall Street with Glass-Steagall?

The opposition to these policies will be fierce. If there is to be a positive outcome to this battle, an informed citizenry must do its part--intervening, educating, inspiring. That's why you need the EIR Daily Alert more than ever.

TUESDAY, NOVEMBER 22, 2016

Volume 3, Number 65

EIR Daily Alert Service

P. O. Box 17390, WASHINGTON, DC 20041-0390

- Only Global Solutions, Based on New Principles, Can Work
- Tulsi Gabbard Meets with Donald Trump Regarding Syria
- Robert Kagan Throws in the Towel, Complains U.S. Is Becoming 'Solipsistic'
- War Party Moving To Preempt Trump-Putin Reset
- Syrian Army Makes More Progress in Aleppo
- Duterte Gives OK to Nuclear Power for Philippines
- Europe Will Suffer from Maintaining Russia Sanctions
- Former Chilean Diplomat Confirmed, 'We Will Joyfully Welcome Xi Jinping'
- Duterte and Putin Establish Philippines-Russia Cooperation
- François Fillon, Pro-Russian Thatcherite, Wins First Round of French Right-Wing Presidential Primary

EDITORIAL

Only Global Solutions, Based on New Principles, Can Work



SUBSCRIBE (e-mail address must be provided.)

EIR DAILY ALERT SERVICE

- \$100** one month (introductory)
- \$600** six months
- \$1,200** one year (includes EIR Online)

Name _____

Company _____

Address _____

City _____ State _____ Zip _____ Country _____

Phone (_____) _____

E-mail _____

For mobile users,
EIR Daily Alert Service
is available in html

I enclose \$ _____ check or money order

Make checks payable to

EIR News Service Inc.

P.O. Box 17390, Washington, D.C. 20041-0390

Please charge my MasterCard Visa
 Discover Am Ex

Card Number _____

Signature _____

Expiration Date _____

EIR can be reached at:

www.larouchepub.com/eiw

e-mail: fulfillment@larouchepub.com

Call 1-703-297-8434